

TOWN OF WRENTHAM, MASSACHUSETTS

RULES AND REGULATIONS GOVERNING THE SUBDIVISION OF LAND

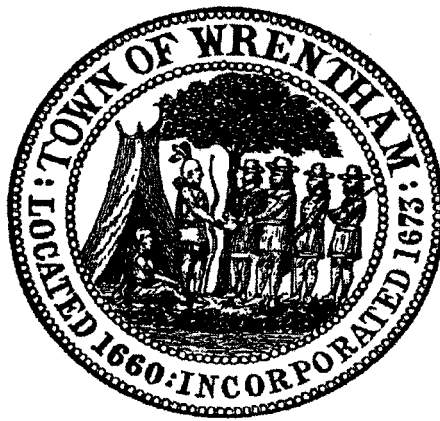

Adopted July 3, 1985
Revised September 22, 1988
Revised May 17, 1995
Revised September 6, 2000
Revised June 5, 2002
Revised November 19, 2003
Revised June 16, 2016
Revised October 21, 2020

1.	GENERAL PROVISIONS	4
1.1	TITLE	4
1.2	AUTHORITY	4
1.3	PURPOSE	4
1.4	CONSTRUCTION	5
1.5	WAIVER OF REQUIREMENTS	5
1.6	EFFECTIVE DATE	5
2.	DEFINITIONS	6
3.	PROCEDURE FOR SUBDIVISION OF LAND	9
3.1	GENERAL	9
3.2	PLANS THOUGHT NOT TO REQUIRE APPROVAL UNDER THE SUBDIVISION CONTROL LAW	9
3.3	PLANS TO BE APPROVED UNDER THE SUBDIVISION CONTROL LAW	11
4.	GENERAL REQUIREMENTS FOR LAND SUBDIVISION	21
4.1	PUBLIC WATER SUPPLY	21
4.2	PUBLIC SEWERS AND PRIVATE ON-LOT SYSTEMS	21
4.3	PUBLIC UTILITIES	21
4.4	STREETS	21
4.5	DRAINAGE	23
4.6	EARTH REMOVAL	24
5.	DESIGN STANDARDS	25
5.1	STREETS	25
5.2	DRAINAGE	26
5.3	WATER	32
5.4	EASEMENTS	33
5.5	LOTS	33
5.6	OPEN SPACES	33

TABLE OF CONTENTS – continued

5.7 PROTECTION OF NATURAL FEATURES 34

5.8 FIRE ALARM INSTALLATION 34

6. IMPROVEMENTS IN SUBDIVISIONS 35

6.1 DRAINAGE 35

6.2 WATER 36

6.3 UNDERGROUND SERVICES 36

6.4 LIGHTING 37

7. STREET CONSTRUCTION 38

7.1 STREET GRADING 38

7.2 ROADWAYS 38

7.3 CURBING 40

7.4 STREET SIGNS 40

7.5 PLANTING STRIPS 41

7.6 SIDE SLOPES 41

7.7 LOAMING 41

7.8 MONUMENTS AND MARKERS 41

7.9 STREET LINES 42

8. ENVIRONMENTAL AND COMMUNITY ASSESSMENT REPORT 43

8.1 GENERAL 43

8.2 CONTENT 43

8.3 APPROACH 43

9. GENERAL PROVISIONS 45

9.1 SANITARY FACILITIES 45

9.2 CLEANING UP 45

9.3 INSPECTION AND CONTROL 45

9.4 AUTHORITY OF THE PLANNING BOARD 46

TABLE OF CONTENTS – continued

APPENDIX A – FORMS & SCHEDULES 47
APPENDIX B – FIGURES 79

1. GENERAL PROVISIONS

1.1 TITLE

These Rules and Regulations shall be known as the Rules and Regulations Governing the Subdivision of Land in the Town of Wrentham and may be cited as Wrentham Subdivision Rules and Regulations.

1.2 AUTHORITY

These Rules and Regulations are adopted pursuant to the statutory rule making authority of Section 81Q of Chapter 4I of the General Laws for the purposes set forth in Section 1.3 of these Rules and Regulations.

1.3 PURPOSE

The Planning Board as elected representative of the residents of the Town of Wrentham adopts these Rules and Regulations to effect the following purposes in regard to the subdivision of land:

- a. to ensure compliance with the general statement of purpose declared in section 81 M of the Subdivision Control Law, Chapter 41 of the General Laws; and
- b. to ensure technical compliance with the requisites of the Subdivision Control Law, MGL c.41 §§81K – 81GG
- c. to ensure compliance with the zoning ordinances and bylaws of the Town of Wrentham; and
- d. to ensure compliance with the general statement of purpose declared in Section 2A of Chapter 808 of the Acts of 1975; and
- e. to ensure compliance with the Massachusetts Environmental Protection Act, Sections 61, 62 Chapter 30 of the General Laws; and
- f. to protect the right of every resident of the Town of Wrentham to clean air and water; freedom from excessive and unnecessary noise; and to the natural, scenic, historic, and aesthetic qualities of his/her environment as declared in Article XCVII (97) of the Constitution of the Commonwealth of Massachusetts; and
- g. to realize the congressional mandate of the National Environmental Policy Act, Sections 43213 et seq. of Title 42 of the United States Code, which declares that local government in cooperation with the Commonwealth and the Federal Government is a responsible agency for restoring and maintaining environmental quality; and
- h. to encourage, permit, and ensure planned, orderly growth in the Town of Wrentham; and
- i. to provide for compatible development and best use of the Town's land and resources; and
- j. to assist other agencies of government in the Town of Wrentham in planning for and providing essential services to all residents.

1.4 CONSTRUCTION

These Rules and Regulations shall be liberally construed and applied to promote the purposes set forth in Section 1.3 of these Rules and Regulations.

1.5 WAIVER OF REQUIREMENTS

Where necessary or convenient to accomplish the purposes of these Rules and Regulations, the Board may waive any requirement(s) of these Rules and Regulations. Any such waiver shall be upon vote of a majority of the Board.

1.6 EFFECTIVE DATE

These Rules and Regulations are to be effective July 3, 1985 and from that time shall supersede all prior rules and regulations governing the subdivision of land in the Town of Wrentham.

2. DEFINITIONS

2.1 Unless a contrary intention or definition is clearly expressed herein, terms and words defined in the Subdivision Control Law, Chapter 41 of the General Laws, shall have the meaning given therein for purposes of these Rules and Regulations.

2.2 The following terms and words shall have the meaning defined herein:

ABUTTER: As used in these Rules and Regulations means an owner of land as listed in the most recent real property tax list, certified by the Board of Assessors, whose real property is within 300 feet of the boundaries of a proposed subdivision of land as shown on the definitive plan.

APPLICANT: As used in these Rules and Regulations means a person, corporation, real estate trust, or other legal entity who/which makes application to this Board for approval of a plan for subdivision of land pursuant to Chapter 41 of the General Laws or who/which makes application to this Board for determination that a plan of land does not require approval under the Subdivision Control Law, Chapter 41 of the General Laws.

ARTERIAL STREET: As used in these Rules and Regulations means a proposed or existing street, which, in the opinion of the Board, is to be used for major through traffic with a volume in excess of 2400 vehicles in a representative 24-hour period.

BOARD: As used in these Rules and Regulations means the Planning Board of the Town of Wrentham.

COLLECTOR STREET: As used in these Rules and Regulations means a proposed or existing street which, in the opinion of the Board, is to be used to connect several minor streets with a volume in excess of 400 vehicles in a representative 24-hour period.

DEAD-END STREET: A street or network of streets having only one shared access/egress point intersecting a THROUGH-STREET which said access/egress point is fully accessible to customary traffic and emergency vehicles. Any street which is not a THROUGH-STREET (see Figure 6 - DEAD END STREETS).

DEFINITIVE PLAN: As used in these Rules and Regulations means a proposed plan for subdivision of land submitted pursuant to Chapter 41 of the General Laws and Sections 3.32 et seq. of these Rules and Regulations for approval of the Board.

ENGINEER: As used in these Rules and Regulations means a person who is registered and/or lawfully permitted to practice professional engineering in the

Commonwealth of Massachusetts.

ENVIRONMENTAL AND COMMUNITY ASSESSMENT REPORT: As used in these Rules and Regulations means a comprehensive, technical analysis and report by the Applicant which is required to be submitted to the Board pursuant to Section 8 of these Rules and Regulations.

GENERAL LAWS: As used in these Rules and Regulations means the General Laws of the Commonwealth of Massachusetts, Ter. Ed.

INDUSTRIAL-COMMERCIAL STREET: As used in these Rules and Regulations means a proposed or existing street which, in the opinion of the Board, is to be used to provide local access to industrial-commercial enterprises.

LAND SURVEYOR: As used in these Rules and Regulations means a person who is registered and/or lawfully permitted to practice land surveying in the Commonwealth of Massachusetts.

LOT: As used in these Rules and Regulations means an- area of land in one ownership, with definite boundaries, used, or available for use, as the site of one or more buildings.

MassDOT: As used in these Rules and Regulations means the Massachusetts Department of Transportation.

MINOR STREET: As used in these Rules and Regulations means a proposed or existing street which, in the opinion of the Board, is to be used primarily for residential purposes with a volume of less than 400 vehicles in a representative 24-hour period.

PERSON: As used in these Rules and Regulations means a human being or corporation, real estate trust, or other legal entity.

PRELIMINARY PLAN: As used in these Rules and Regulations means a proposed plan for subdivision of land submitted pursuant to Chapter 41 of the General Laws and Sections 3.31 et seq. of these Rules and Regulations for the information of and analysis by the Board and other regulatory agencies of the Town of Wrentham.

STREET: As used in these Rules and Regulations means the right of way or taking and includes the traveled way, curbing, grass strips, sidewalks, drainage facilities, and utilities.

SUBDIVISION: As used in these Rules and Regulations means the division of a tract of land into two or more lots and shall include re-subdivision, and when

appropriate to the context, shall relate to the process of subdivision or the land or territory subdivided; provided, however, that the division of a tract of land into two or more lots shall not be deemed to constitute a subdivision within the meaning of the Subdivision Control Law if, at the time when it is made, every lot within the tract so divided has frontage on (a) a public way or a way which the Clerk of the Town certifies is maintained and used as a public way, or (b) a way shown on a plan theretofore approved and endorsed in accordance with the Subdivision Control Law, or (c) a way in existence when the Subdivision Control Law became effective in the Town, having, in the opinion of the Planning Board, sufficient width, suitable grades and adequate construction to provide for the needs of vehicular traffic in relation to the proposed use of the land abutting thereon or served thereby, and for the installation of municipal services to serve such land and the buildings erected or to be erected thereon. Such frontage shall be of at least such distance as is then required by zoning or other ordinance or bylaw, if any, of the Town for erection of a building, on such lot, and if no distance is so required, such frontage shall be of at least twenty feet. Conveyances or other instruments adding to, taking away from, or changing the size and shape of, lots in such a manner as not to leave any lot so affected without the frontage above set forth, or the division of a tract of land on which two or more buildings were standing when the Subdivision Control Law went into effect in the town in which the land lies into separate lots on each of which one of such buildings remains standing, shall not constitute a subdivision.

SUBDIVISION CONTROL: As used in these Rules and Regulations means the lawful authority of the Board pursuant to the Constitution of the Commonwealth of Massachusetts, Chapter 41 of the General Laws, these Rules and Regulations, and other statutes, ordinances, and bylaws to regulate the subdivision of land in the Town of Wrentham.

THROUGH-STREET: A street or segment thereof, which is open at both ends that allows vehicular access and egress to any and all locations outside the immediate area along more than one segment of the street network (see Figure 7 - COMPARISON OF DEAD-END VERSUS THROUGH-STREETS).

UTILITIES: As used in these Rules and Regulations means gas, electric, water, drainage, fire, cable television, and related and ancillary services.

WETLANDS: As used in these Rules and Regulations means any lands or waters subject to Sections 40, 40A of Chapter 131 of the General Laws and/or the watershed protection district bylaw of the Zoning Bylaw of the Town of Wrentham.

WDPW: As used in these Rules and Regulations means the Department of Public Works of the Town of Wrentham.

3. PROCEDURE FOR SUBDIVISION OF LAND

3.1 GENERAL

No person shall make a subdivision within the meaning of the Subdivision Control Law of any land within the Town, or proceed with the improvement or sale of lots in a subdivision, or the construction of ways, or the installation of municipal services therein, unless and until a definitive plan of such subdivision has been submitted and approved by the Board as hereinafter provided.

3.2 PLANS THOUGHT NOT TO REQUIRE APPROVAL UNDER THE SUBDIVISION CONTROL LAW

Any owner of land located in the Town or their representative who wishes to cause to be recorded in the Registry of Deeds or to be filed with the Land Court a plan of land, and who believes that the plan does not require approval, under the Subdivision Control Law, may submit the plan to the Planning Board accompanied by the necessary evidence to show that the plan does not require approval under the Subdivision Control Law.

3.21 PROCEDURE FOR SUBMISSION OF PLAN THOUGHT NOT TO REQUIRE APPROVAL

The Applicant shall file an original mylar of the ANR Plan with three (3) copies that conform to the content requirements of Section 3.22 to the Planning Board office.

- 1) The Applicant shall provide a .pdf version of the application packet and plan by email, compact disc or thumb drive.
- 2) The Applicant shall submit two (2) copies of the application Form 1 (See Appendix). One (1) copy of the application must contain the original signature of the record owner and/or the applicant. If the owner and applicant are not the same and both signatures are not provided on the application, the Board will accept a letter signed by the owner that authorizes the Applicant to proceed with the application on their behalf.
- 3) The application must be accompanied by the corresponding application fee pursuant to the Planning Board's fee schedule.
- 4) The Applicant shall provide a copy of the deed on the property as well as a certification by the Town Treasurer that there are no outstanding taxes owed on the property(ies) in question.
- 5) Once the application is considered complete by the Planning Board staff, it shall be filed with the Office of the Town Clerk and stamped with the date of receipt and shall be considered "filed". Incomplete applications shall be returned to the applicant.
- 6) Once the application is deemed complete and filed with the Town Clerk, the Applicant shall be notified by Planning Board staff and placed on the next available agenda of a regularly-scheduled Planning Board meeting.
- 7) One (1) copy of the plan shall be submitted to the DPW Superintendent

and one (1) copy to the Fire Department for review and comment.

3.22 REQUIREMENTS FOR SUBMISSION OF PLAN THOUGHT NOT TO REQUIRE APPROVAL:

In addition to the requirements listed in Section 3.21 above, all ANR plans must contain the following information:

- 1) Name of record owner(s) of land shown on the plan;
- 2) Name, signature and seal of the surveyor and/or engineer who prepared the plan;
- 3) Names of all adjacent abutters as they appear on the most recent Assessor's records and, if the Applicant has knowledge of any changes subsequent to the most recent records, the names of the present owners of abutting land;
- 4) Location of all man-made structures and significant natural features, including existing buildings and structures, stone walls and/or guardrails, rock outcrops, steep slopes, wetlands, easements, rights of way, water courses, drains, streets, ways, scenic roads, major trees and such other references known to the applicant to sufficiently identify the land to which the plan relates and to sufficiently identify any existing impediments to access upon the land. A topography plan, shown at two (2)-foot contours, shall be provided where slopes exceeding 15% may impede access upon the land between the street and the proposed location of the structure or house;
- 5) Town of Wrentham Assessor's map number, block number and lot number;
- 6) All boundary lines, dimensions and areas of all lots to which the plan relates;
- 7) The remaining frontage and total area of the land in the ownership of the Applicant in all cases wherein there shall result in the creation of a new lot or revised lot lines;
- 8) North arrow, date of survey and scale (both numeric and bar);
- 9) Delineation of all streets and ways, both sides, indicating the width of pavement with a statement of whether or not all streets and ways shown or referred to are public or private ways;
- 10) A brief description of the intent of the plan; what the applicant is looking to accomplish through approval;
- 11) A locus map at a scale of 1" = 800' or other such scale acceptable to the Planning Board to depict the location of the site in relation to the surrounding area;
- 12) Appropriate reference(s) shown on the plan to any variance(s) granted by the Zoning Board of Appeals or other decisions/permits affecting the land included in the plan;
- 13) The statement, "Approval Under the Subdivision Control Law Not Required" together with sufficient space for the signatures of the Planning Board members and the date of endorsement;

- 14) A note shall appear on the plan stating that the endorsement of the Planning Board should not be construed to be a determination of conformance with the Zoning By-Laws of the Town of Wrentham for all lots affected;
- 15) A note shall appear on the plan stating that the endorsement of the Planning Board should not be construed to be a determination of conformance with the General By-Laws of the Town of Wrentham for all lots affected.

In general, a plan of division of land into two (2) or more lots that does not require approval under the Subdivision Control Law, shall meet one (1) of the following requirements:

- (1) Each lot therein has sufficient frontage on (a) a public way, or on a way which the Clerk of the city or town certifies is maintained and used as a public way, or (b) a way shown on a plan heretofore approved in accordance with the Subdivision Control Law, or (c) a way in existence when the Subdivision Control Law became effective; having, in the opinion of the Board, sufficient width, suitable grades, and adequate construction to provide for the needs of vehicular traffic in relation to the proposed use of the land abutting thereon or served thereby; and for the installation of municipal services to serve such land and the buildings erected or to be erected thereon.
- (2) Each lot has standing on it a building, such building having been standing at the time of adoption of subdivision control laws in the Town.

3.23 If the Board determines that the plan does not require approval it shall, without a public hearing, endorse on the plan the words "Planning Board approval under Subdivision Control Law not required". Said plan shall be signed and returned to the applicant and the Board shall notify the Town Clerk of its action by submission of a signed plan and copy of the application.

If the Board determines that the plan does require approval under the Subdivision Control Law, it shall so inform the Applicant and return the plan. The Board shall also notify the Town Clerk of its determination.

3.3 PLANS TO BE APPROVED UNDER THE SUBDIVISION CONTROL LAW

3.31 Preliminary Plan

A preliminary plan of any proposed subdivision exceeding six (6) lots shall be submitted to the Planning Board and to the Board of Health for the tentative approval, modification or disapproval by each Board. Three (3) copies of Form 2 (see Appendix) shall be submitted and accompanied by the original and nine (9) copies of the preliminary plan on sheets measuring 24" x 36", and eight (8) additional copies on sheets measuring 11" x 17", along with the appropriate fee (see Planning Board's Fee Schedule). The Applicant shall also provide a .pdf version of the plan and other application submittals and reports by email,

compact disc or thumb drive. The preliminary plan shall not be deemed to have been submitted to the Planning Board until the application forms and plans have been delivered to the Board at a regular or special meeting. Receipt will be acknowledged by signature on each copy of the application form, two (2) of which will be immediately returned to the Applicant or his agent. Thereafter, he shall file by delivery or by certified mail, a notice with the Town Clerk stating the date of submission of the plan and accompanied by a receipted copy of the application form.

3.311 Plan Form

The preliminary plan shall be prepared by an engineer and surveyor and be drawn clearly and legibly on tracing paper at a horizontal scale of 1" = 40', and in the case of profiles, at a horizontal scale of 1" = 40' and a vertical scale of 1" = 4".

3.312 Plan Content

The preliminary plan shall show clearly the following:

- a. Subdivision name, boundaries, north point, date, scale, legend and title "Preliminary Plan";
- b. Names of the record owner and the Applicant and the name or names of the engineer or surveyor;
- c. Names of all abutters as determined from the most recent tax list and such others to whom notices are to be sent;
- d. Existing and proposed lines of streets, easements, and any public areas within the subdivision, in a general manner;
- e. Proposed system of drainage including adjacent natural waterways, in a general manner;
- f. Proposed sewerage system and water distribution system;
- g. Approximate boundary lines of proposed lots with approximate areas and dimensions;
- h. Names, approximate locations and widths of adjacent streets;
- i. The existing topography of the land at five (5) - foot intervals based on the U.S. Coast and Geodetic Survey Base, and field check of all low elevation and high elevation points;
- j. The proposed topography of the land at five (5) - foot intervals. The proposed topography to be indicated by dashed lines with proposed elevations shown, enclosed in blocks;
- k. Other existing site features (regardless of proposed construction) including water bodies, wetlands, buildings, stone walls, rock outcroppings, and trees five (5) inches in diameter or the perimeter of heavily wooded areas; and
- l. Zoning classification of the area.

3.313 Approval or Disapproval

The Board and the Board of Health shall act upon the preliminary plan and its accompanying materials in accordance with Chapter 41 of the General Laws.

Approval, if given, does not constitute approval of a subdivision, but does facilitate the procedure in securing approval of the definitive plan.

Any plan submitted by the Applicant to the Board in advance of the definitive plan which does not conform to the requirements hereof pertaining to a preliminary plan shall not be considered to be a preliminary plan, nor shall such plan be given any approval by the Board.

3.32 Definitive Plan

3.321 Submission

Any Applicant who submits a definitive plan of a subdivision to the Board for approval in accordance with the Subdivision Control Law shall file the following with the Board:

- a. An original drawing of the definitive plan and fifteen (15) contact prints (seven (7) copies on 24" x 36" sheets and eight (8) copies on 11" x 17" sheets). The prints are to be black line on white background;
- b. Four (4) copies of a Stormwater Drainage/Hydrological Report prepared in accordance with Section 5.2, which has been stamped and signed by an Engineer. Said report shall also indicate the date of preparation (and any revision date subsequent to its initial submission);
- c. Signed receipt from the Office of the Board of Health demonstrating the Applicant's submission to said Office of two (2) copies of the definitive plan on sheets measuring 24" x 36", Environmental and Community Assessment Report, as required by Section 8 and the Stormwater Drainage/Hydrological Report, noting the most recent revision dates on said comments;
- d. Three (3) copies of Application Form 3 (see Appendix). The Applicant shall state in the application the time within which the required work on the ground will be completed;
- e. The Applicant shall provide a .pdf version of the plan and other application submittals and reports by email, compact disc or thumb drive;
- f. The appropriate fee (see Planning Board's Fee Schedule);
- g. A list of all abutters together with the address of each as determined from the most recent local tax list certified by the Board of Assessors. An abutter is any property owner within 300 feet of the boundary of the proposed subdivision;
- h. A location plan of the subdivision at a scale of 1" = 200", showing the exterior lines of all proposed streets in the subdivision and their location in relation to one (1) or more existing streets or portions thereof;
- i. A sketch plan, acceptable to the Board, showing a prospective street layout for any adjacent land owned or controlled by the owner or Applicant of the subdivision;
- j. Sixteen (16) copies of an Environmental and Community Assessment Report, as required by Section 8; and

- k. The definitive plan shall not be deemed to have been submitted to the Planning Board until the application, plan, and fee herein required have been delivered to the Planning Board at a regular or special meeting. Receipt will be acknowledged by signature of a majority of the Board on each copy of the application, two of which will be returned to the Applicant. Thereafter, the Applicant shall file by delivery or by certified mail a notice with the Town Clerk stating the date of submission of plan and accompanied by a receipted copy of the application form.

3.322 Plan Form

The definitive plan shall be prepared by an engineer and surveyor and shall be clearly and legibly drawn at a scale of 1" = 40' in black India ink upon sheets of tracing cloth or Mylar, 24" x 36", with 1.5" border except on the left side which shall be 2.25".

If multiple sheets are used, they shall be accompanied by an index sheet showing the entire subdivision.

3.323 Plan Content

The definitive plan shall contain or be accompanied by the following information:

- a. Subdivision name, boundaries, true north point, date and scale;
- b. Names and addresses of present record owner(s) and Applicant, and name(s) of the engineer and surveyor who prepared the plan; certificates and seals of the engineer and surveyor; and a certificate that all surveying conforms to the requirements of the Massachusetts Land Court;
- c. Names of all abutters as determined from the most recent tax list;
- d. Zoning district boundaries, if any, and the General Zoning Classification of the area;
- e. Existing and proposed lines of streets, lot numbers (as assigned by the Assessors Department), rights-of-way, easements, and any public or common areas within the subdivision. (The proposed names of streets are subject to review and approval by the Board.);
- f. Location, names and present widths of streets bounding, approaching, or within reasonable proximity of the subdivision;
- g. Boundary lines, areas in square feet, and dimensions of all proposed lots, with all lots designated numerically and in sequence;
- h. Sufficient data including lengths, bearings, radii, and central angles to determine the exact location, direction and length of every street line, lot line and boundary line and sufficient survey data referred to existing permanent monuments such that these lines may be readily established on the ground based on the North American Datum of 1983 (units in feet) or its successor;
- i. Corner (i.e., intersection) and stopping sight distances shall be shown in plan and profile view, respectively, along roadways and at intersections

within and adjoining the proposed subdivision in accordance with “A Policy on Geometric Design of Highway and Streets Latest Edition (Country 2001) published by the American Association of State Highway and Transportation Officials”;

- j. Sufficient permanent benchmarks, referred to the North American Vertical Datum of 1988 (unit in feet) or its successor, properly identified;
- k. Location of natural waterways, water bodies and wetlands, watershed protection, aquifer protection and flood plain districts within and adjacent to the subdivision. In addition, a notation on the coversheet of the definitive plan shall be signed by the Wrentham Conservation Commission or its authorized agent certifying that the lands and related buffers subject to the provisions of MGL c.131 §40 and Article 16 of the Town of Wrentham Bylaws are accurately shown on the definitive plan or that no such lands and related buffers extend within the proposed subdivision;
- l. Monuments at all points of curvature and at changes in directions of street side lines or where designated by the Board;
- m. Size, material, type and location of existing and proposed storm drains, water mains, hydrants and sewers including all appurtenances, within and adjacent to the subdivision;
- n. Suitable space to record the action of the Board and the signatures of the members of the Board on each sheet of the definitive plan;
- o. Major site features, such as existing stone walls, fences, buildings, rock ridges, rock outcroppings, swamps, trees over five (5) inches in diameter, or the perimeter of heavily wooded areas;
- p. In the event that a preliminary plan has not been submitted, the existing topography of the land will be shown based on a benchmark set to the North American Vertical Datum of 1988 (units in feet) or its successor. The proposed topography of the land will be shown at five (5) - foot intervals, based on an actual survey. The proposed topography will be indicated by dashed lines with proposed elevations shown enclosed in blocks;
- q. The location of the proposed fire alarm system;
- r. The location of the proposed street lighting system;
- s. A separate plan for each proposed street, including bridges, in the subdivision, at a horizontal scale of 1" = 40', showing for each such proposed street: side lines, center line, points of tangency, length of tangents, length of curves, and the location of permanent monuments and bench marks, together with all lot lines, buildings, and other major features within 40 feet of the exterior lines of such street. The layout plan shall also show the size and location of all proposed water mains, valves and hydrants within the street, together with their appurtenances. On the same sheet there shall be drawn cross-sections of the proposed street, properly located and identified by station number, at such intervals along the street as will indicate adequately any variations in its section. These shall be supplemented where necessary by lines on the plan showing the width and location of proposed roadways, planting strips, gutters, sidewalks and

similar physical features.

Directly above or below the plan of each proposed street, a profile shall be drawn at a horizontal scale of 1" = 40' and a vertical scale of 1" = 4' showing for such street existing centerline grades in fine black solid line, existing exterior left side line in fine black short dash line, existing exterior right side line in fine black long dash line, and proposed finished centerline grades in heavy solid line. Proposed grade elevations shall be shown by figures at beginning and end of the street at 50 - foot station intervals and at the beginning and end of all vertical curves. Rates of gradient in percentage shall also be shown. All elevations shall refer to North American Vertical Datum of 1988 (units in feet) or its successor. Profiles shall also indicate the location of any intersecting public or private ways, and location of existing and proposed storm drains, water mains, sewers, other public utilities, and their appurtenances.

3.324 Review of Board of Health as to Suitability of the Land

At the time of filing of the definitive plan, the Planning Board shall transmit to the Board of Health, in accordance with the Subdivision Control Law, one (1) contact print of the definitive plan. The Board of Health shall, within the time prescribed by the Subdivision Control Law after receipt of the plan, report to the Planning Board in writing, approval or disapproval of said plan, in accordance with the Subdivision Control Law.

3.325 Review of WDPW and Wrentham Fire Department

At the time of filing of the definitive plan, the Planning Board shall transmit one (1) copy of the definitive plan to the WDPW and the Fire Department. These agencies may review the plan and submit recommendations to the Board.

3.326 Public Hearings

Before approval, modification and approval, or disapproval of the definitive plan is given, a public hearing shall be held by the Board in accordance with the Subdivision Control Law. Legal notice of the public hearing shall be given by the Board to the Applicant and to all abutters as appear on the most recent local tax list. Publication of the legal notice and the mailing of the notices to the abutters shall be at least 14 days prior to the public hearing.

3.327 Approval, Modification or Disapproval

The Board shall approve, modify or disapprove the definitive plan in accordance with the requirements of MGL c.41 §81K – 81GG.

3.328 Certificate of Approval

The action of the Board in respect to said plan shall be by vote, copies of which shall be filed with the Town Clerk and sent by certified mail to the Applicant. If the Board modifies or disapproves said plan, it shall state in its vote the reason for its action. Final approval, if granted, shall be endorsed on the original drawing of the definitive plan by the signatures of a majority of the Board, but not until the

statutory 20 - day appeal period has elapsed following the filing of the certificate of the action of the Board with the Town Clerk, and said Clerk has notified the Board in writing that no appeal has been filed.

Within 30 days after the return to the Applicant of the definitive plan, as approved and endorsed, he shall obtain and furnish to the Board four prints of said plan showing any modifications and final endorsement. Prints shall be black line on white background. No lots shall be released by the Board until the Applicant has filed with the Board the above prints.

Approval of the definitive plan shall not be deemed to constitute the laying out or acceptance by the Town of any streets within a subdivision.

3.329 Performance Guarantee

Before endorsement of a definitive plan of a subdivision, the Applicant shall agree to complete the required improvements specified in Sections 6 and 7 for all lots in the subdivision, such construction and installation to be secured by one (1), or a combination of the following, as determined by the Board.

a. Final Approval with Bonds or Surety

The Applicant shall either file a surety company performance bond or a deposit of money or approved negotiable securities in an amount determined by the Board to be sufficient to cover the cost of all or any part of the improvements specified in Sections 6 and 7 not covered by a covenant, under "b" below. Such bond or security, if filed or deposited, shall be contingent on the completion of such improvements within one year of the date of the bond or surety. A time extension may be granted by the Board at its discretion. See Planning Board's Fee Schedule for required Bond Estimate fee.

b. Final Approval with Covenant

The Applicant shall file a covenant, Form 4 (see Appendix) executed and duly recorded by the owner of record, running with the land, whereby such ways and services as specified in Sections 6 and 7 not covered by bond or deposit under "a" above, shall be provided to serve any lot before such lot may be built upon or conveyed, other than by mortgage deed.

3.330 Reduction of Bond or Surety

The sum of any required bond or other surety, or the amount of any deposit held hereunder may from time to time be reduced by the Board and the obligations of the parties thereto released by the Board in whole or in part (see Appendix Form 5). See Planning Board's Fee Schedule for required Bond Reduction fee.

3.331 Release of Performance Guarantee

Upon the completion of improvements required in Sections 6 and 7, security for the performance of which was given by bond, deposit, covenant, or upon the performance of any covenant with respect to any lot, the Applicant may request and agree on terms of release with the Board, or he may send by certified mail to the Town Clerk a written statement in duplicate that the construction or installation in connection with such bond, deposit or covenant has been completed in accordance with the requirements contained in Sections 5, 6 and 7. The Town Clerk shall forthwith furnish a copy of said statement to the Board.

If the Board determines that said improvements have been completed, it shall release the interest of the Town in such bond and return the bond or the deposit to the person who furnished the same, and/or release the covenant by appropriate instrument, Certificate of Release of Covenant (see Appendix Form 6) duly acknowledged, with a copy to the Building Inspector. If the Board determines that said improvements have not been completed, it shall, within 45 days, specify to the Applicant by certified mail and to the Town Clerk the details wherein said improvements fail to comply with its rules and regulations.

3.332 Evidence of Satisfactory Performance

Before the Board will release the interest of the Town in the performance bond or deposit or, in the case of approval with covenant, issue a release of covenant:

- a. The Applicant shall file with the Board a certified copy of a separate layout plan (with accompanying cross-sections and profile) for each street in the subdivision (or, in the case of approval with covenant, of the street or streets serving the lots for which a release is desired). Certification shall be by the engineer and surveyor employed by the Applicant at his expense, and shall indicate that all easements, streets, sidewalks, sewers, storm drains, and water mains and their appurtenances have been constructed in accordance with the lines and grades of said plan and are accurately located as shown thereon;
- b. The Board shall obtain from the Applicant a statement in writing from the WDPW (see Appendix - Form 7) that all work under its jurisdiction required by these Rules and Regulations has been inspected and completed in each street or streets serving the lots covered by the surety), including storm drains, water mains and appurtenances, hydrants, bridges and sidewalks and that it has approved the construction and materials used in the performance of such work; and
- c. In addition to five (5) black-line prints, an electronic file and media as specified in the Town of Wrentham Computer File Standards of said layout plan and related profile(s) shall be submitted referencing the location of streets and related improvements to the State Plane Coordinate System and the North American Datum of 1983 (units in feet) or its successor. In lieu of the electronic file, a fee as stipulated in the Planning Board Fees

Schedule shall be paid by the Applicant to cover the expenses of the Town to update its maps and related records.

3.333 Phasing of Subdivision Construction

Paragraph "a" below shall be noted on any portion of an approved definitive subdivision plan, which is to be recorded at the Norfolk County Registry of Deeds. Documentation that said portion of the plan has been recorded shall be furnished to the Planning Board prior to release of any Covenant.

- a. No less than 48 hours beforehand, the Wrentham Planning Board and the WDPW shall receive written notice from the Applicant of the commencement of clearing and excavation within a subdivision site related to the installation of required improvements. Approval of this plan shall be deemed no longer in effect (i.e., rescinded) if:
 1. Construction of improvements required under Section 6 and 7 (of the WSRR) has not commenced within 24 months from the date of endorsement of the definitive subdivision plan; or,
 2. Construction of improvements required under Section 6 and 7 (of the WSRR) has not commenced within six (6) months after the initiation of the related clearing and rough grading of land within a subdivision site.

Said periods of performance may be extended, provided the Applicant requests and the Board votes, prior to the expiration of their respective 24 - month or six (6) - month periods, an extension of up to 12 additional months on the period for which construction shall begin. (Prior to granting an extension, the Board shall consider the justifications for the delays and whether a reasonable basis exists to expect appreciable progress with the installation of required improvements over the next 12 - month period.) Prior to the expiration of each extension period, the Board (based on the same considerations) may thereafter grant additional 12 - month extensions. All extensions shall be recorded at the Norfolk County Registry of Deeds and documentation of said recording shall be provided to the Board prior to the release of the Covenant. In the event that no extensions have been requested or granted, any subsequent plans to subdivide the site shall be subject to the Rules and Regulations Governing the Subdivision of Land existing at the time of such submission.

- b. Once construction of improvements required under Sections 6 and 7 has commenced, said construction shall be completed within 36 months from the date of endorsement of the definitive subdivision plan or within 24 months from the initiation of the related clearing and rough grading of land within a subdivision site, whichever is later. Failure to complete said construction as so stated shall allow assumption of the performance

guarantee at any time thereafter by the Planning Board to complete said construction, unless the Applicant requests and the Board votes, prior to the expiration of the applicable 36 or 24 - month period, an extension of up to 12 additional months on the period to allow the completion of construction. (Prior to granting an extension, the Board shall consider the justifications for the delays and whether a reasonable basis exists to expect appreciable progress with the installation of required improvements over the next 12 - month period.) Prior to the expiration of each extension period, the Board (based on the same considerations) may thereafter grant additional 12 - month extensions. As a condition of granting an extension, the Board may require additional funds to be provided by the Applicant to cover any increase in construction costs or potential need to repair existing improvements during the extension period.

4. GENERAL REQUIREMENTS FOR LAND SUBDIVISION

4.1 PUBLIC WATER SUPPLY

All lots within the subdivision shall be provided with water either by connection to the Town of Wrentham's public water supply system or by suitable driven wells approved by the Board of Health, Town of Wrentham. Water mains and their appurtenances must be installed in accordance with the rules and regulations of the WDPW and approved by the Board. Size of water mains shall be as recommended by the WDPW and as required by the Board.

4.2 PUBLIC SEWERS AND PRIVATE ON-LOT SYSTEMS

4.21 Public sewers will be required if, in the opinion of the Board, connection to the Town of Wrentham's public sewerage system is feasible.

4.22 Where private on-lot sewerage systems are installed, such systems shall be designed in accordance with the Board of Health, Town of Wrentham, Massachusetts, rules and regulations, and the State Sanitary Code, Article XI, of the Department of Public Health, Commonwealth of Massachusetts, "Minimum Requirements for the Disposal of Sanitary Sewage in Unsewered Areas".

4.3 PUBLIC UTILITIES

4.31 Electricity

Electrical power lines shall be installed underground and in accordance with the requirements of the Massachusetts Department of Public Utilities and the Board (see Figure 1.)

4.32 Telephone

Telephone lines shall be installed underground and in accordance with the requirements of the Massachusetts Department of Public Utilities and the Board (see Figure 1.)

4.33 Gas

Gas supply lines shall be installed underground and in accordance with the requirements of the Massachusetts Department of Public Utilities and the Board (see Figure 1.)

4.4 STREETS

4.41 Minor Streets

4.411 Width

Street layouts shall not be less than 45 feet in width. Streets which, in the opinion of the Board, may become collector streets must be at least 50 feet in width.

4.412 Grades

Grades of less than one (1) percent (1.0%) or more than eight (8) percent (8%) shall be approved only under exceptional circumstances by the Board.

4.413 Cross-section

Streets shall be constructed in accordance with the standards as shown on the "Typical Cross-sections for Street Layouts". (See Figure 1 and Section 5.1.)

4.42 Collector Streets

4.421 Width

Street layouts shall not be less than 50 feet in width. Streets which, in the opinion of the Board, may become arterial streets must be at least 80 feet in width.

4.422 Grades

Grades of less than one percent (1.0%) or more than seven (7) percent (7%) shall be approved only under exceptional circumstances by the Board.

4.423 Cross-section

Streets shall be constructed in accordance with the standards as shown on the "Typical Cross-sections for Street Layouts". (See Figure 1 and Section 5.1.)

4.43 Arterial Streets

4.431 Width

Street layouts shall not be less than 80 feet in width.

4.432 Grades

Grades of less than one (1) percent (1%) or more than five (5) percent (5%) shall be approved only under exceptional circumstances by the Board.

4.433 Cross-section

Streets shall be constructed in accordance with the standards as shown on the "Typical Cross-sections for Street Layouts". (See Figure 1 and Section 5.1.1)

4.44 Commercial - Industrial Streets

4.441 Width

Street layouts shall not be less than 60 feet.

4.442 Grades

Grades of less than one (1) percent (1%) or more than five (5) percent (5%) shall be approved only under exceptional circumstances by the Board.

4.443 Cross-section

Streets shall be constructed in accordance with the standards as shown on the "Typical cross-sections for Street Layouts". (See Figure 1 and Sections 5, 6, and 7.)

4.45 Dead-End Streets (See Section 2.2)

Dead-end streets shall not be longer than 1,500 feet.

No dead-end shall be extended off an existing dead-end unless it is extended to an existing roadway or a through street.

4.46 Rotary Circles or Cul-de-sacs and Back-up Strips

The layout of rotary circles or cul-de-sacs shall have a radius of not less than 60 feet nor (for purposes of maintaining "vital access" to the lot frontage) greater than 75 feet at the terminus of dead-end streets (see Figure 2.)

4.47 Temporary Rotary Circles or Cul-de-sacs and Back-up Strips (see Figure 2)

The Board requires the construction of temporary rotary circles or cul-de-sacs on dead-end streets where possible extension into adjacent land can be anticipated.

4.48 Street Grades

Street grades shall follow the natural contour of the land as nearly as is possible so as to minimize excessive cuts and fills.

4.5 DRAINAGE

4.51 Stormwater management for each subdivision shall accomplish the following:

- a. Proposed conditions shall replicate the hydrological conditions of the ground and surface waters prior to the development;
- b. Have an acceptable future operation and maintenance plan covering methods and execution of the plan to ensure BMPs and stormwater management system functions as designed;
- c. Have a beneficial effect on the natural and human environment;
- d. Be appropriate for the site, given the site's specific physical constraints, i.e., limit rock cut, depth to groundwater;
- e. Provide a sufficient level of health and environmental protection during the construction phase;
- f. Provide proper management prior to the discharge of such runoff onto adjacent property owned by others, into the existing storm drainage system, or wetland resources listed in the Wetland Protection Act Regulations, 310 CMR 10.00; and
- g. Maintain the same total rate of runoff being discharged off the site between pre and post-development conditions as well as endeavor to do the same with total volume of runoff.

4.52 Storm drainage shall be designed in accordance with Section 5 and installed in

accordance with Section 6.

4.6 EARTH REMOVAL

- 4.61** The tentative or final approval of a subdivision plan by the Planning Board shall not be construed as authorizing the removal of material from the premises, except in connection with the construction of streets shown on the plan.
- 4.62** All other earth removal within subdivisions shall be in accordance with the Rules and Regulations Governing Earth Removal for the Town of Wrentham, Massachusetts.
- 4.63** Top soil for lots shall be stockpiled on site and used on the site. Excess topsoil from lots shall be removed from site if necessary, upon completion of the finish grading operation provided that it does not constitute earth removal per Zoning By-Laws, Article 14 and it is approved by the Wrentham Building Inspector.

4.7 TOWN ACCEPTANCE

Completed utilities and roads are required to satisfactorily pass one complete winter prior to presentation to the Town for acceptance. Prior to the Planning Board signing off on road acceptance plans, the appropriate fee as stipulated in the Planning Board's Fee Schedule shall be paid.

1 **5. DESIGN STANDARDS**

2 Subdivisions shall be designed in accordance with the following specific
3 standards.

4 **5.1 STREETS**

5
6 **5.11 Location**

7
8 **5.111** Streets in the subdivision shall be coordinated with each other and with the
9 existing street system in a manner satisfactory to the Board, with due regard to
10 securing safety and convenience of travel.

11
12 **5.112** Provision satisfactory to the Board shall be made for the proper extension of
13 streets, easements, or for access to adjoining property which is not yet
14 subdivided.

15
16 **5.113** Reserve strips prohibiting access to streets or adjoining property shall not be
17 permitted, except where, in the opinion of the Board, such strips shall be in the
18 public interest.

19
20 **5.12 Cross-sections**

21 Cross-sections shall be in accordance with the standards as shown on the
22 "Typical Cross-sections for Street Layouts" which are herewith made a part of
23 these Rules and Regulations (see Figure 1).

24
25 **5.13 Alignment and Intersections**

26
27 **5.131** Alignment shall be in accordance with the standards shown on Table 1.

28
29 Table 1.
30 Minimum Radii of the Centerline of Curved Streets

Type of Street	Radius
Minor	150 ft.
Collector	300 ft.
Arterial	500 ft.
Industrial-Commercial	300 ft.

31
32 **5.132** Streets shall be laid out so as to intersect as nearly as possible at right angles.
33 No street shall intersect any other street at less than a 60 - degree angle.

34
35 **5.133** Property lines at street intersections shall be rounded or cut back to provide for a
36 curb radius of not less than 25 feet.

37
38

39 **5.134 Intersection Centerline Offsets**
40 For all types of streets except arterial, the centerline offset distance between
41 intersections shall be a minimum of 200 feet and for arterial shall be 500 feet.
42

43 **5.135 Sight Distances**
44 Proposed streets shall be located to afford no less than the minimum corner (i.e.,
45 intersection) and stopping sight distances along intersecting streets, both within
46 and adjoining the subdivision, in accordance with “A Policy on Geometric Design
47 of Highway ad Streets Latest Edition (Country 2001) published by the American
48 Association of State Highway and Transportation Officials”.
49

50 **5.14 Bridges**
51 Bridges shall be designed in accordance with Massachusetts Department of
52 Public Works "Bridge Design Standards" in force at the time of filing of the
53 application. Design of bridges shall be approved by the Division of Waterways of
54 the Massachusetts Department of Public Works where required.

55 **5.2 DRAINAGE**

56 **5.21 Design Criteria**

57
58
59 **5.211** Stormwater management systems shall be designed in accordance with
60 “Managing Stormwater in Massachusetts Volume One: Stormwater Handbook
61 and Volume Two: Best Management Practices (BMP) Manual”, published by the
62 Massachusetts Department of Environmental Protection (DEP), dated March
63 1997 and as may be amended regardless of whether the subdivision is subject to
64 the Wetlands Protection Act. The methodologies for evaluating hydrology and
65 stormwater management are to be consistent with the “Hydrology Handbook For
66 Conservation Commissioners”, published by the DEP, dated March 2002.
67

68 **5.212** Stormwater management, including detention, retention, and infiltration systems,
69 must be designed to prevent any increase or decrease in peak and total flow
70 rates for the two (2), 10, 50 and 100 - year Soil Conservation Service Type III
71 design storms. In addition, drainage systems shall include water quality/settling
72 basins or water quality inlets that treat and detain the first flush of stormwater. Its
73 design shall be based on a 5/10 - inch rainstorm for an average of at least six (6)
74 hours, unless within a critical area as defined by DEP, in which case a 1.0-inch
75 rainstorm during the same time period shall be considered. Stormwater basins
76 shall be sized and designed for a 100 - year storm event.
77

78 **5.213** The average rainfall intensity in inches per hour shall be obtained from the
79 Technical Paper No. 40 (TP-40) Atlas.
80

81
82 **5.214** Runoff analysis shall be calculated using Technical Release No. 55, Urban
83 Hydrology for Small Watersheds, Second Edition, prepared by the U.S. Soil

84 Conservation Service methodology.

85
86 **5.215** The use of relatively small open drainage basins (e.g. “rain gardens”) and
87 unlined channels located within each sub-drainage area of a given subdivision
88 shall normally serve as the method of treating and managing stormwater flows.
89 Other methods may be allowed if the Board determines, based on submitted
90 documentation by the Applicant, that it, as compared to the system design that
91 will normally be required, would; 1) be more appropriate given site-specific
92 environmental conditions; 2) offer at least the same level of managing and
93 treating stormwater flows; and, 3) not present inordinate costs to maintain, repair
94 and replace in the future. In such cases, the requirements imposed herein upon
95 stormwater basins shall apply to any alternative drainage facility.

96
97 **5.216** Test borings to document soils and high ground water elevations are required at
98 proposed locations of all stormwater basins. The bottom of all proposed
99 stormwater basins designed to detain drainage flows (rather than to retain flows
100 so as to ultimately create a wetland filter) shall be at least two (2) feet higher than
101 the annual high groundwater elevation as adjusted by factors promulgated by the
102 Wrentham Board of Health in designing subsurface wastewater treatment
103 systems.

104
105 **5.217** The hydrologic soil unit shall be identified and submitted with the calculations.
106 Stormwater basins shall be sized and designed for a 100 - year storm
107 event and drainage pipes connecting to these systems shall be sized for a 25 -
108 year storm event. Calculations and a narrative shall be submitted to document
109 the effects of the 100 - year storm on the drainage pipes and demonstrate how
110 all stormwater discharges to the basins. All culverts shall be designed for the 50
111 - year storm event.

112
113 **5.218** Emergency spillways will be designed to allow passage of the design outflow
114 without causing the water elevation to rise above a pre-designed elevation. A
115 freeboard of one (1) foot will be required between the detained water elevation
116 and the top of the embankment during peak design conditions.

117
118 **5.219** Embankments along drainage basins shall have a 4:1 slope. If a 4:1 slope is
119 readily feasible, but would result in the disturbance of significant environmental
120 conditions, a 3:1 slope may be allowed. In either case, the deepest portion of the
121 basin shall not exceed three (3) feet and shall remain separated at least two (2)
122 feet above the annual high water table (unless designed to retain flows as
123 specified in Section 5.216).

124
125 **5.220** Definitive Subdivision Plans shall include a design detail and cross section of the
126 proposed stormwater basin or subsurface treatment facility, which shall include
127 details of the invert construction at both the inlet and discharge.
128

129 **5.221** A stormwater basin and related appurtenances shall be located within the
130 subdivision they are serving unless drainage would be directed to a stormwater
131 management system elsewhere that was designed to be readily upgraded to
132 accept flows from the proposed or other nearby development (see
133 Section 5.245).
134

135 **5.222** A stormwater basin and related appurtenances outside a proposed street layout
136 shall be located either on:
137

- 138 a. A parcel of land separate from any building lot that extends no less than
139 20 feet in width to an existing or proposed street; or,
- 140 b. Within a portion of a building lot that would be located outside its minimum
141 lot area as required in that zoning district.

142
143 However, to avoid potential conflict between basins or other drainage
144 improvements and other activities within the lot as noted in paragraph b
145 above, said minimum lot area, where no stormwater basin would be
146 allowed, must also be shown to comply with build-factor and Watershed
147 Protection District area requirements of the Wrentham Zoning Bylaws (i.e.
148 Sections 5.2e. and 6.2). (For example, a basin may be located within a
149 half-acre portion of an 1½ acre building lot within an R-43 Zoning District,
150 provided the remaining acre is configured to meet Section 6.2. and has
151 sufficient area outside the Watershed Protection District.)
152

153 **5.223** In Open Space Preservation Developments, a stormwater basin and related
154 appurtenances shall not be located within the minimum upland and/or minimum
155 total area required for the Common Open Space. (For example, a stormwater
156 basin may be located within an “excess” upland area, which is outside the
157 minimum required total area of Common Open Space (i.e. 30% of the total land
158 area within a given OSPD) as well as the 50% of the minimum Common Open
159 Space area that must be comprised of upland.)
160

161 **5.224** A drainage basin and related appurtenances that are within a building lot shall be
162 located toward the side or rear property lines of said lot. However, a basin may
163 be located toward the front portion of the lot if it would lessen impact on sensitive
164 environmental conditions elsewhere or serve another public interest as
165 determined by the Planning Board, provided outflows from the basin can be
166 properly directed away from nearby streets and other properties. Furthermore, a
167 basin shall not further reduce or effectively leave less than 50% of the area
168 between the required frontage distance and the location of where a principal
169 structure would be constructed on a lot to be comprised of wetlands and/or
170 existing grades of greater than 15% in order to ensure viable vehicular access to
171 the lot. In no case, shall the outermost edge of a stormwater basin be located
172 less than 25 feet from any roadway layout.
173

174 **5.225** Stormwater basins with greater than 500 cubic feet in capacity shall be screened
175 from adjacent lots and roadways by a greenbelt of trees and shrubs not more
176 than 15 feet apart planted in two staggered rows. Such trees or shrubs shall be
177 not less than 8 feet in height at the time of planting.
178

179 **5.226** To facilitate future maintenance of improvements, designated access from a
180 street to any stormwater basin shall not exceed a slope of three (3) horizontal
181 feet to every one (1) vertical foot at any point along its course.
182

183 **5.227** Stormwater basins and any parcel they are located thereon (if outside of any
184 building lot) shall be conveyed to the Town upon acceptance of any related street
185 layouts by the Town. In cases when the street layout and related improvements
186 are to be privately maintained after the final release of the subdivision
187 performance guarantee, Articles of Organization for establishing a Property
188 Owners Association within the development shall be submitted to and receive
189 approval from Town Counsel as to its form before the endorsement of the
190 Definitive Subdivision Plan. Said Articles of Organization shall thereafter be
191 recorded at the Norfolk County Registry of Deeds and a copy of which shall be
192 provided to the Planning Board prior to the release of the Subdivision Covenant.
193

194 **5.23 Drain and Channel Sizes**

195
196 **5.231** Capacity of drainage pipes, culverts and drainage channels shall be determined
197 on the basis of 25 - year storm intensity. Computation shall be based on full
198 development of all tributary areas upgradient of each system. Runoff analyses
199 shall be calculated by using the "Rational Method". The runoff coefficients are
200 shown on Table 2. All drains shall be sloped to provide for a minimum velocity of
201 2 feet per second and a maximum design velocity of 10 feet per second under
202 full flow conditions. Where natural drainage courses would otherwise be
203 obstructed, culverts or similar structures approved by the Board shall be installed
204 to restore natural drainage. Capacity of these structures shall be determined on
205 the basis of 50 - year storm intensity.
206
207

Table 2. Runoff Coefficients for Rational Formula

Type of Drainage Area	Runoff Coefficient, C*
Business:	
Downtown areas	0.70 – 0.95
Neighborhood areas	0.50 – 0.70
Residential:	
Single-family areas	0.30 – 0.50
Multi-units, detached	0.40 – 0.60
Multi-units, attached	0.60 – 0.75
Suburban	0.25 – 0.40
Apartment dwelling areas	0.50 – 0.70
Industrial:	
Light areas	0.50 – 0.80
Heavy areas	0.60 – 0.90
Parks, cemeteries	0.10 – 0.25
Playgrounds	0.20 – 0.40
Railroad yard areas	0.20 – 0.40
Unimproved areas	0.10 – 0.30
Lawns:	
Sandy soil, flat, 2%	0.05 – 0.10
Sandy soil, average, 2 – 7%	0.10 – 0.15
Sandy soil, steep, 7%	0.15 – 0.20
Heavy soil, flat, 2%	0.13 – 0.17
Heavy soil, average, 2 – 7%	0.18 – 0.22
Heavy soil, steep, 7%	0.25 – 0.35
Streets:	
Asphaltic	0.70 – 0.95
Concrete	0.80 – 0.95
Brick	0.70 – 0.85
Drives and walks	0.75 – 0.85
Roofs	0.75 – 0.95
* Higher values are usually appropriate for steeply sloped areas and longer return periods because infiltration and other losses have a proportionally smaller effect on runoff in these cases.	

Primary Reference: ASCE, 1992 and Rossmiller, 1980

- 210
211 **5.232** Drainage pipes shall have a minimum diameter of 12 inches. In general, they
212 should be designed to flow full with the hydraulic gradient at the crown. In
213 determining the capacity of reinforced concrete pipe drains, the Manning
214 Roughness Coefficient for friction "n" shall equal 0.013. In determining the
215 capacity of high-density polyethylene (HDPE) pipe drains, the Manning
216 Roughness Coefficient for friction "n" shall equal 0.012.
217
- 218 **5.233** If roadway sub-drainage is required, rigid perforated HDPE pipe of appropriate
219 size shall be used. Installation shall conform to that shown in Figure 5.
220
- 221 **5.24 Drainage Collection System**
222
- 223 **5.241** Within the subdivision roadway, stormwater runoff shall not be permitted to flow
224 upon the surface for a distance greater than 300 feet. Catchbasins shall be
225 located on both sides of the roadway on continuous grades at intervals of not
226 more than 300 feet, at all low points in the roadway, and near the corners of the
227 roadway at intersecting streets.
228
- 229 **5.242** All catchbasins shall be connected to the drainage system through manholes.
230 Manholes shall be provided at all changes in alignment, grade or drainage pipe
231 size. The maximum distance between manholes shall not exceed 300 feet.
232
- 233 **5.243** All catch basins shall have four (4) - foot sumps.
234
- 235 **5.244** The maximum depth of any portion of the drainage system shall be 10 feet below
236 finished grades.
237
- 238 **5.245** Where adjacent property is not subdivided, provision shall be made for extension
239 of the drainage system. In such cases, the Board may require additional area to
240 be set aside to allow future expansion of a stormwater basin, adjustments to the
241 size of drainpipes, or similar measures which could ultimately accommodate
242 additional flows from the adjacent property.
243
- 244 **5.246** Where existing drainage systems discharge onto the property being subdivided,
245 provision shall be made for accepting that drainage into the proposed drainage
246 system.
247
- 248 **5.247** Private Drains: Perimeter drains, cellar drains or any other form of drainage
249 collection system within a building lot shall neither be connected into manhole
250 and catch basin structures within a street nor discharge within 20 feet of a street
251 layout.
252
253

254 **5.248** Stormwater basins and other related or similar improvements that are designed
255 to primarily manage drainage flows within certain lots (as opposed to primarily
256 benefiting areas outside of said lots) shall be the sole responsibility of the current
257 and future owners of said lots to properly maintain and replace, when necessary.
258 The design of said improvements shall nonetheless be subject to approval by the
259 Board in terms of its potential effect on drainage systems along proposed and
260 existing roadways. Documents shall be recorded at the Norfolk County Registry
261 of Deeds allowing the Town to enter upon said lots to make any necessary
262 repairs to said drainage improvements therein should flow from said
263 improvements exceed original design parameters and undermine the drainage
264 system along nearby public ways. In such an event, a municipal lien shall be
265 placed on the lot for the cost of such work performed by the Town unless the lot
266 owner provides prior compensation to the Town.

267 **5.3 WATER**

268
269 **5.31 Mains**

270 Public water mains shall be no less than eight (8) inches in diameter.
271

272 **5.32 Hydrants**

273 There shall be a hydrant at a maximum of 500 - foot intervals except in
274 Commercial and Industrial zones, where there shall be a hydrant at a maximum
275 of 300 - foot intervals. Each hydrant shall be served directly from the water main
276 through a 6" lateral connection. It shall be gated with a 6" gate valve
277 attached to the "T Branch" and shall have two (2) 1.5" hose outlets and one
278 (1) 4.5" pump outlet. All hydrant threads are to be N.S.H.T. The 4.5" pump outlet
279 shall be at least 18" above the finished grade. Flange of the hydrant shall be level
280 with the finished sidewalk surface. For location of hydrants, see Section 7.63.
281

282 **5.33 Connection to Public System**

283 Where the municipal water system is located within 2,000 feet of a proposed
284 subdivision, said subdivision shall connect to the municipal water system solely
285 at the expense of its Applicant. The Board may waive this requirement in lieu of
286 the Town receiving from the Applicant proportionate funding toward the extension
287 of the public water system in consideration of the number of lots within the
288 proposed subdivision, the distance from the closest connection and other
289 relevant factors. In no case should this requirement be waived if a proposed
290 subdivision would or could contain 20 or more lots.
291

292 Where a subdivision is not to be connected to the municipal water system upon
293 the construction of its roadways, it shall have installed therein:

- 294
295 a. A private on-site well on each lot to serve the domestic water demand of
296 its principal use in accordance with applicable local and state regulations;
297 b. An alternative fire suppression system acceptable to both the Wrentham

298 Fire Department and the Board that complies with National Fire Protection
299 Association (NFPA) Standards; and
300 c. "Dry water mains" in accordance with applicable DPW regulations in any
301 street where, in the opinion of the Planning Board, municipal water service
302 will become accessible within a period of five (5) years.
303

304 **5.34 Valves**

305 Valves shall be located in such number and locations that lines by individual
306 block may be isolated for maintenance purposes, including the Town water
307 system connection points.

308 **5.4 EASEMENTS**

309
310 **5.41** Easements for storm drains, sanitary sewers or water mains across lots, or
311 centered on rear or side lot lines, shall be provided for the Town where
312 necessary and shall be at least 30 feet wide. No easement shall be permitted
313 across land of others unless an agreement in proper form (see Appendix –
314 Form 8) is obtained permitting such an easement.
315

316 **5.42** Easements extending no less than 15 feet from the uppermost elevation of a
317 stormwater basin, swale, channel and all other forms of conveyances or flow
318 paths associated with stormwater management shall be required.
319

320 **5.43** Where a subdivision is traversed by a watercourse, drainage way, channel or
321 stream, the Board may require that there be conveyed to the Town without cost a
322 storm water easement of adequate width (20 - 100 feet - centered approximately
323 on the center line of the watercourse, drainage way, channel or stream)
324 depending upon the width of the stream. This easement shall conform
325 substantially to the lines of such watercourse, drainage way, channel or stream,
326 and shall provide for construction or other necessary purposes in relation thereto.
327

328 **5.44** No building or on - lot sewerage system shall be erected within an easement.
329

330 **5.45** All easements shown on said plans shall be conveyed to the Town and recorded
331 prior to any lot being sold or any covenant being released.

332 **5.5 LOTS**

333 All lots within the subdivision shall comply with the area, frontage and width
334 requirements of the Zoning By-Laws for the Town of Wrentham, Massachusetts
335 in effect at the time of application.

336 **5.6 OPEN SPACES**

337 Before approval of a plan, the Board may also require the plan to show usable
338 open space such as trails, a park or parks suitably located for playground or
339 recreational purposes, providing for light and air and protecting the natural

340 resources in accordance with the Subdivision Control Law. The useable open
341 space (park or parks) shall not be unreasonable in area in relation to the land
342 being subdivided and to the prospective uses of such land. Final disposition of
343 such area shall be in accordance with the Subdivision Control Law.

344 **5.7 PROTECTION OF NATURAL FEATURES**

345 Due regard shall be shown for all natural features, such as large trees, groups of
346 trees, other major vegetation, watercourses, scenic points, historic spots, and
347 similar community assets, which, if preserved, will add attractiveness and value to
348 the subdivision. No trees over five (5) inches in diameter shall be cut except for
349 roadways, driveways, and foundations without approval of the Board.

350 **5.8 FIRE ALARM INSTALLATION**

351 The fire alarm system shall be installed in accordance with the requirements of the
352 Wrentham Fire Department.
353

6. IMPROVEMENTS IN SUBDIVISIONS

In subdivisions, the ways shall be constructed in accordance with Section 7 and municipal services installed in accordance with the following specific requirements:

6.1 DRAINAGE

The construction of the drainage system, including methods of construction and quality of materials used, shall be in conformity with the definitive plan and the details shall conform with the details of the most recent edition of MassDOT Standard Spec. for Highways and Bridges unless specific exception is made by the Board.

- 6.11 All catchbasins and manholes shall be constructed of pre-cast concrete, cement brick or of cement concrete blocks laid in cement mortar and plastered on the outside as approved by the Board. A detail of their construction shall be shown on the Definitive Subdivision Plan and shall meet applicable Massachusetts Highway Department Standard Specifications.
- 6.12 Catchbasin frames and covers shall be LeBaron Foundry Type LF248-2 or equal (see Figure 4), and manholes shall be provided with a No.4 State Standard Manhole Frame and Cover (see Figure 4). Their cast iron shall conform to ASTM A48 Class 30 with H-20 wheel load and all casting shall be made in the USA.
- 6.13 A granite inlet curb is to be furnished for all catchbasins and the installation shall be as directed by the WDPW and the Board. On each end of the granite inlet curb shall be a six-foot transition segment of vertical granite curbing.
- 6.14 All catchbasins and manholes shall be constructed in accordance with the "Typical Cross-section of Catchbasins and Manholes¹" (see Figure 5).
- 6.15 Reinforced Concrete Drain Pipe shall be installed under any roadway. Design specifications and installations must follow the requirements of the MassDOT, 2006 Project Development and Design Guide. Some basic requirement guidelines to follow are:
 - 1. Preferably, pipes will be placed at a 5-foot depth to avoid frost penetration.
 - 2. The minimum size of a trunk or lateral line shall be 12 inches.
 - 3. All pipes shall be placed in a straight line. Where this is not cost effective on large diameter pipes, bends may be considered by the Board.
 - 4. All pipe joints and connections shall be mortared or gasketed (per manufacturer's specifications) to prevent infiltration or exfiltration.

Please refer to the table below for type of pipe required based on diameter, minimum and maximum cover:

Recommended Cover (Reinforced Concrete Drain Pipe)

Diameter III Inches	Modified Min-Max	Extra Strength Min-Max	Class III Min-Max	Class IV Min-Max	Class V Min-Max
6	24 in. to 23 ft				
8	24 in. to 17 ft				
10	24 in. to 13 ft				
12	36 in. to 12 ft	24 in. to 13 ft	18 in. to 12 ft	12 in. to 20 ft	6 in. to 35 ft
15	36 in. to 12 ft	24 in. to 13 ft	18 in. to 12 ft	12 in. to 20 ft	6 in. to 35 ft
18	36 in. to 12 ft	24 in. to 13 ft	18 in. to 12 ft	12 in. to 20 ft	6 in. to 35 ft
21	18 in. to 12 ft	12 in. to 20 ft	6 in. to 35 ft		
24	18 in. to 12 ft	12 in. to 20 ft	6 in. to 35 ft		
27	18 in. to 12 ft	12 in. to 20 ft	6 in. to 35 ft		
30	18 in. to 12 ft	12 in. to 20 ft	6 in. to 35 ft		
36	18 in. to 12 ft	12 in. to 20 ft	6 in. to 35 ft		
42	18 in. to 12 ft	12 in. to 20 ft	6 in. to 35 ft		
48	18 in. to 12 ft	12 in. to 20 ft	6 in. to 35 ft		
60	18 in. to 12 ft	12 in. to 20 ft	6 in. to 35 ft		
72	18 in. to 12 ft	12 in. to 20 ft	6 in. to 35 ft		

1. Maximum cover shown is measured from finish grade.
2. Minimum cover shown is measured from subgrade for construction traffic.
3. Heavy weight cast iron pipe is required for subgrade cover less than 6 inches for laterals. For trunk line, use Class V reinforced concrete pipe.
(Source: MassDOT 2006 Project Development and Design Guide, Chapter 8 Drainage and Erosion Control.)

6.16 Where required by the WDPW and the Board, stone or reinforced concrete headwalls shall be installed. All open-ended pipes over 15 inches in diameter shall be provided with a vertical grate protection permanently attached to the end of the pipe. Horizontal distance between the vertical bars of the grate shall be approximately six (6) inches.

6.17 Subdrains shall be installed alongside slopes or beneath paved areas when deemed necessary by the Board to avoid groundwater from flowing onto, across or beneath roadways. Subdrains shall be constructed as shown in the Massachusetts Highway Department Standard Specifications and in these Rules and Regulations (see Figure 5).

6.18 Prior to the release of the Subdivision Covenant, an as-built plan shall be submitted to the Board by the Engineer or Land Surveyor indicating thereon the invert grades of all drainage infrastructure, including catch basins and manholes as well as base and side slope elevations of all stormwater basins within the subdivision. The Engineer or Land Surveyor shall certify that the elevations and grades shown on this plan represent the elevations and grades as constructed.

6.2 WATER

The water system shall be installed in accordance with the definitive plan and shall be in conformity with the rules of and at the direction of the WDPW.

6.3 UNDERGROUND SERVICES

- 6.31** All water mains and laterals within the exterior lines of the street shall be installed not less than five (5) feet below the finished grade of the street.
- 6.32** All water mains and laterals, shutoff valves and hydrants, culverts, manholes, storm drains, sewers, gas mains, and underground light, power, telephone and communication conduits within the exterior lines of the street shall be installed and inspected prior to any backfilling of trenches or other covering of the above services. The above services shall be installed prior to the completion of the roadway foundations. Fill material used for backfilling shall be placed and compacted by hand or by vibrating equipment around and above units to a depth of one foot above these units before completing the remaining filling.
- 6.33** Catchbasin gratings, manhole covers, water gates, etc., shall be set so that they are ½" below the finished surface of the street and shall be set in a bed of high-strength cement mortar prior to the application of the finished bituminous concrete pavement. Sufficient time for "setting" of mortar shall be allowed. (Minimum time shall be 24 hours.)

6.4 LIGHTING

The location, height, intensity, and bulb type (e.g., florescent, sodium, incandescent) of all lighting fixtures shall be shown. The direction of illumination and methods to eliminate glare onto adjoining properties must also be shown.

Light standards are restricted to a maximum of 20 feet in height. Luminaries shall be shielded to prevent light shining beyond the lot lines onto neighboring properties.

Street lighting shall be placed at a minimum at the following: all intersections, the end of cul-de-sacs, and any other locations as designated by the Board and/or DPW Superintendent.

7. STREET CONSTRUCTION

7.1 STREET GRADING

- 7.11** The entire area of each street within its exterior lines and its adjoining sloped areas shall be cleared of all stumps, brush, roots, rocks, boulders and like material and also of all trees not intended for preservation.
- 7.12** Within each street, the roadway (including any required shoulders) shall be excavated for the full length and width to a depth of at least 15" below the finished surface or filled to a sub-grade the top of which is 15" below the finished surface. If the soil is soft or yielding, or contains rocks, boulders, clay, sand pockets, peat or other material detrimental in the opinion of the Board to the subgrade, such material shall be removed to such additional depth as required by the WDPW and the Board, and replaced with compacted material.
- 7.13** The roadway subgrade shall be inspected and approved prior to any further roadway construction.
- 7.14** Adequate dust control shall be provided at all times for all roadway construction.

7.2 ROADWAYS

- 7.21** Roadways shall be constructed for the full length and width of all streets within the subdivision shown on the definitive plan and in accordance with the "Typical Cross section for Street Layouts" (see Figure 1).

7.22 Paving

All roadways shall be paved to a thickness as specified herein with two courses of Class I Bituminous Concrete Pavement, Type I-1. The aggregate shall be composed, mixed and laid out in two courses as specified in Section 460 of the MassDOT Standard Specifications for Highways and Bridges, dated 1967, and as specifically set forth in Section 460.20 thereof. No bituminous concrete pavement shall be placed when the temperature falls below 40°F.

7.23 Roadways for Minor or Collector Streets

1. Roadways shall be provided with an aggregate base course, binder course, and a surface course.
 - a. The aggregate subbase course shall consist of well-graded gravel spread over the subgrade and compacted with appropriate equipment to 95% maximum density to a total depth of eight (8) inches. The material is to be compacted in four (4) - inch layers. The finished surface of the aggregate base course shall be four (4)"

of dense graded crushed gravel, which may be modified at the discretion of the Supt. WDPW and shall conform to the "Typical Cross-section for Street Layouts" (see Figure 1).

- b. The binder course of MassDOT, Class I Bituminous Concrete Pavement, Type I-1, (coarse-graded - $\frac{3}{4}$ - inch maximum size aggregate) shall be applied and rolled to a thickness of 2.5" with a 10 - ton tandem roller.
- c. Before the surface course is applied, the surface of the binder course shall be swept clean and dry, and tack coated with emulsion designated RS-1 by machine at a rate of 1,110 gal./square yard and then leveled with a Leveling Course where settling has occurred before the application of the Surface Course. The Surface Course shall consist of MassDOT Class I Bituminous Concrete Pavement, Type I-1 (fine graded). It shall be applied on the binder course and shall be rolled to a thickness of 1.5" with a 10 - ton tandem roller. The surface course shall be hand tamped around structures and curbing.

7.24 Roadways for Arterial and Industrial-Commercial Streets

1. Roadways shall be provided with an aggregate base course, a binder course, and a surface course
 - a. The aggregate sub-base course spread over the subgrade and compacted with appropriate equipment to 95% maximum density to a depth of twelve (12) inches. The material is to be compacted in four (4) - inch layers. The four (4)" of dense grade crushed stone or crushed gravel of the aggregate base course shall be treated with $\frac{3}{4}$ gal. of M.C. asphalt per square yard and shall conform to the "Typical Cross-sections for Street Layouts" (see Figure 1).
 - b. The binder course of MassDOT, Class I Bituminous Concrete Pavement, Type I-1 (coarse graded) shall be applied and rolled to a thickness of 3.5 inches with a 15 - ton tandem roller.
 - c. Before the surface course is applied, the surface of the binder course shall be swept clean and dry and leveled where needed, and tack coated with emulsion designated RS-1 by machine spraying at a rate of 1/10 gal./square yard. The surface course shall consist of MassDOT Class I-1 Bituminous Concrete Pavement, Type I-1 (fine graded). It shall be applied on the binder Course and shall be rolled to a thickness of 1-1.5" with a fifteen-ton tandem

roller. The surface course shall be hand-tamped around structures and curbing.

7.25 Density of Pavement

The density and tests of all pavements shall be such that they conform to Section 460.21 of the MassDOT Standard Specifications for Highways and Bridges.

7.3 CURBING

7.31 Curbing shall be installed along each edge of the roadway in all streets as shown on the definitive plan.

7.32 Curbing required hereunder shall be standard granite curbing, MassDOT Type VA-4. Other options may be considered by the Planning Board. On any horizontal curve having a radius less than 400 feet, granite curbing shall be required. All required standard (vertical) granite curbing, Type VA-4 shall be installed in accordance with Figure 8 of these Subdivision Rules and Regulations.

7.4 STREET SIGNS

Street signs shall be supplied and installed by the developer and approved by the WDPW. They shall bear the names of the streets as indicated on the definitive plan and shall be erected by the subdivider at all intersections of streets within the subdivision and at the intersection of any street of the subdivision with a public way. These signs normally will be placed at the mid-point of the arc and at the back of the sidewalk. The names of both streets shall appear on the signpost at street intersections.

7.5 SIDEWALKS

7.51 Sidewalks of the width shown on the "Typical Cross-sections for Street Layouts" (see Figure 1) shall be constructed on both sides of each roadway on all streets shown on the definitive plan. Utilities shall not be placed beneath paved sidewalks.

7.52 Sidewalks shall have a finished grade in relation to the finished grade of the roadway as shown on the "Typical Cross-sections for Street Layouts" (see Figure 1).

7.53 In constructing all sidewalks, the material shall be removed for the full width of the sidewalk to subgrade at least 10" below the approved finished grade, and also all soft spots and other material undesirable, in the opinion of the Board, below such subgrade shall be replaced with a good binding material and

compacted to a 95% maximum density. The excavated area shall be filled with select gravel containing some binding material and compacted to 95% maximum density. The final thickness shall not be less than eight (8)" and the surface shall have a pitch parallel to that shown on the applicable cross section plan. Sidewalks shall then be paved and rolled with a two (2) - ton roller to a thickness of 2.5" with bituminous concrete pavement applied in two (2) equal courses. The course shall be of MassDOT Class I Bituminous Concrete Pavement, Type I-1 (fine graded).

7.5 PLANTING STRIPS

- 7.61** Planting strips of a width required by the "Typical Cross-sections for Street Layouts" and in accordance with, and as shown on the definitive plan, shall be provided on each side of the roadway.
- 7.62** The finished grade of such grass strips in relation to the finished grade of the roadway shall be as shown on the applicable cross-section plan.
- 7.63** All hydrants shall be installed a minimum of 24" back of the face of the curb (see Figure 1).
- 7.64** Where natural tree cover is sparse, trees will be planted according to a landscape plan approved by the Board.

7.6 SIDE SLOPES

The area in back of the sidewalk, where slope is required, shall be graded to a slope of three (3)" horizontal to one (1) - foot vertical with rounding at the top and bottom of the slopes, as shown on the "Typical Cross-section". Fieldstone retaining walls may be used to reduce the sloping limits, but not the sloping rate.

7.7 LOAMING

The top six (6)" of grass strips and side slopes shall consist of good quality loam, screened, raked, and rolled with a hand roller to grade. The loam shall be seeded with lawn grass seed applied in sufficient quantity to assure adequate coverage and shall be rolled.

7.8 MONUMENTS AND MARKERS

- 7.91** Monuments shall be installed at all street intersections, at all points of change in direction or curvature of streets and at other points as shown on the definitive plan.
- 7.92** Granite or concrete monuments not less than three (3) feet six (6) inches in length dressed to six (6)" x six (6)" in section at the top, and not less than six (6)" by six (6)" in section at the bottom shall be provided and shall be set to finish grade as shown on plans. The exact location point shall be indicated by a hole

having a diameter of ¼ - inch. After the bound has been permanently set, the hole shall be drilled into the top of the bound to a depth of ½ - inch.

7.93 No permanent monuments shall be installed until all construction, which could destroy or disturb the monuments is completed. After the bounds have been set, where appropriate, bituminous concrete shall be placed around the bounds and compacted to the specified thickness.

7.94 A certification shall be made to the Board by the engineer or land surveyor that the bounds have been set as shown on the definitive plan.

7.9 STREET LINES

On Collector, Arterial and Industrial-Commercial Streets, reflectorized pavement markings shall be installed in accordance with MassDOT Standard Specifications for Highways and Bridges, specifically set forth in Section 7.2 and as required by the Board.

8. ENVIRONMENTAL AND COMMUNITY ASSESSMENT REPORT

8.1 GENERAL

The Applicant must file four copies of an environmental and community assessment report with the definitive plan. This report must be prepared by a registered professional engineer and satisfy the requirements of the Board. It is designed to build into the Board's decision-making process an appropriate and careful consideration of the environmental and community aspects of the proposed subdivision of land.

8.2 CONTENT

8.21 Detailed Description of Proposed Action

The report will describe the proposed action, its purpose, where it is located, its time setting and its interrelationship with other projects or proposals.

8.22 Environmental and Community Impact of the Proposed Action

8.221 The report shall describe the primary and secondary environmental and community impacts, both beneficial and adverse, anticipated from the action. The scope of the description shall include construction period and complete project impacts.

8.222 Corrective and protective measures which will be taken as part of the proposed action to minimize adverse impacts shall be described.

8.23 Adverse Impacts Which Cannot be Avoided Should the Proposal be Implemented

The report shall describe the kinds and magnitudes of adverse impacts which cannot be reduced in severity or which can be reduced to an acceptable level but not eliminated.

8.24 Alternatives to the Proposed Actions

The report shall develop, describe, and objectively weigh alternatives to any proposed action which involves significant tradeoff among the uses of available land.

8.25 Irreversible and Irretrievable Commitments of Resources

The report shall describe the extent to which the proposed action, should it be implemented, curtails the diversity and range of beneficial uses of the land and environment.

8.3 APPROACH

8.31 The report will evaluate the following topics for present conditions¹ construction

conditions and environmental controls, and future conditions and environmental controls:

- a. Natural environment
 1. Air pollution
 2. Water, including quantity of drainage and pollution control.
 3. Noise pollution.
 4. Land, including the quantity of earth to be removed from the site.
 5. Wildlife.
- b. Man-Made environment
 1. Surrounding land use
 2. Density
 3. Zoning
 4. Architecture
- c. Public facilities
 1. Water supply and distribution
 2. Storm drainage facilities
 3. Sewage disposal facilities
 4. Solid waste disposal, including trash and garbage
 5. Traffic facilities - Traffic flow patterns within the proposed subdivision roadways and their intersections with existing ways shall be addressed. The following is required:
 - a. The projected number of motor vehicle trips generated by the subdivision estimated for daily and peak hour traffic levels.
 - b. The projected flow pattern including vehicular movements at all intersections described in paragraph 5 above ("Traffic facilities") and other major intersections required by the Board.
 - c. The impact of the projected traffic upon intersecting existing and private ways in relation to existing roadway capacities. Existing and proposed daily and peak hour traffic levels as well as road level capacities should also be given.
 - d. Any other traffic-related information as required by the Board.
 6. Electric power
 7. Gas
- d. Community services
 1. Schools
 2. Recreation
 3. Police
 4. Fire
 5. Public works
- e. Economic considerations
 1. Cost/benefit ratio
 2. Time schedule

9. GENERAL PROVISIONS

9.1 SANITARY FACILITIES

The Applicant shall provide, at his own expense, temporary sanitary facilities for all personnel, either directly or indirectly under his employment and shall be responsible for proper use of such facilities.

9.2 CLEANING UP

9.21 The entire area must be cleaned up so as to leave a neat and orderly appearance free from debris and other objectionable materials. The entire drainage system, including catchbasins, manholes and pipes shall be properly cleaned out.

9.22 Following the completion of this and all other items of work, a final inspection shall be made by the WDPW and the Board.

9.3 INSPECTION AND CONTROL

9.31 The Applicant shall employ, at his own expense, in a manner satisfactory to the WDPW and the Board.

9.32 The contractor shall notify the WDPW when each stage of construction is completed and ready for inspection (see Form 7).

9.33 No succeeding operation shall be started until the prior operation has been approved by the WDPW or the Board. The contractor shall give the WDPW a 24 - hour written notice in hand when an inspection is required.

9.34 The Applicant shall certify in writing to the WDPW and to the Board that the following materials: the aggregate base course, the binder course, the surface course) the sidewalk course) and the curbing mixture are in conformance and are installed as specified in these Rules and Regulations. The Board will require that this certification be submitted by an engineer retained at the Applicant's expense.

9.35 The Applicant shall be responsible for utility, water, sewage, and road maintenance and plowing until the subdivision road(s) is/are accepted as a Town way(s).

9.36 All forms, tables, and figures appended hereto shall be a part of these Rules and Regulations.

9.4 AUTHORITY OF THE PLANNING BOARD

- 9.41** All construction and work on the land and roads which is governed by these Rules and Regulations is subject to the authority of and approval of the Planning Board. Prior to acceptance of the subdivision roads as public ways, all other Boards, including the WDPW, act as the Planning Board's agent.

APPENDIX A - FORMS & SCHEDULES

Form 1 – Application for Endorsement of Plan Believed Not to Require Approval (ANR)

Form 2 – Notice of Submission of Preliminary Plan

Form 3 – Application for Approval of Definitive Plan

Form 4 – Covenant

Form 6 – Certificate of Release of Covenant

Form 7 – Inspection of Construction

Form 8 – Conveyance of Easements and Utilities

Schedule G – Performance Secured by Deposited of Money

Form H – Performance Secured by a Surety Company

Schedule I – Performance Secured by Registered Negotiable Securities (Bonds, Stocks, Public Securities)

Form J – Performance Secured by Bank Passbook

Form K – Performance Secured by Lender’s Agreement

**TOWN OF WRENTHAM
PLANNING BOARD**
WRENTHAM TOWN HALL
79 SOUTH STREET
WRENTHAM, MASSACHUSETTS 02093
P: (508) 384-5441 | F: (508) 384-3174
planning@wrentham.ma.us • www.wrentham.ma.us

**FORM 1
APPLICATION FOR ENDORSEMENT OF PLAN
BELIEVED NOT TO REQUIRE APPROVAL (ANR)**

Application No.: ANR _____ Date: _____

1. OWNER OF RECORD: _____

FULL ADDRESS: _____

PHONE: _____ EMAIL: _____

Deed recorded in the Norfolk County Registry of Deeds Book/Page: _____

2. NAME OF APPLICANT: _____

FULL ADDRESS: _____

PHONE: _____ EMAIL: _____

3. ENGINEER / LAND SURVEYOR: _____

FULL ADDRESS: _____

PHONE: _____ EMAIL: _____

4. NAME OF AGENT / CONTACT PERSON: _____

FULL ADDRESS: _____

PHONE: _____ EMAIL: _____

5. LOCATION OF LAND: on the _____ side of _____
(N, S, E, W) (Street where property has frontage)

_____ feet _____ of _____
(# of feet) (N, S, E, W) (Nearest adjacent street)

Total Acreage _____ Zoning District(s) (including overlay zones) _____

ASSESSORS ID: _____

6. Has the Zoning Board of Appeals, Planning Board or Board of Selectmen granted any variance, exception, or special permit concerning this property? Yes/No
If yes, please explain / list, including dates: _____

7. **AFFIDAVIT** by Engineer / Land Surveyor who stamped/signed the plan that all items required are shown.

I, _____ hereby attest that all above information, required by Wrentham’s Rules and Regulations Governing the Subdivision of Land, is accurately and completely shown on the plan of land dated _____, regarding MAP(s) _____ LOT #(S) _____ located on _____ in the Town of Wrentham.

Engineer/Land Surveyor’s Signature: _____

8. REQUIRED SIGNATURES:

- Please Note: Both required signatures 8A and 8B must be obtained prior to submission.
- Required signatures are the responsibility of the Applicant.
- Failure to obtain all required signatures may cause a delay in processing.

8.A. REQUIRED SIGNATURE(S): APPLICANT AND/OR OWNER: Both the Applicant and at least one Property Owner signature must be submitted.

The undersigned, being the APPLICANT and OWNER(S) named above, hereby applies for Endorsement of a Plan Believed Not to Require Approval by the Planning Board and certifies that, to the best of the APPLICANT’S knowledge and belief, the information contained herein is correct and complete and that said PLAN conforms with the requirements of the Rules & Regulations

Applicant’s Signature _____ Date: _____

Property Owner’s Signature _____ Date: _____
(If Not Applicant)

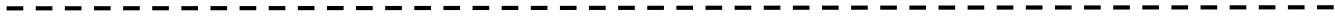

8.B. REQUIRED SIGNATURE: TAX COLLECTOR

To be completed by the **Tax Collector**: The Office of the Tax Collector verifies that there are no outstanding taxes due by the Property Owner to the Town of Wrentham, MA.

Note: Delinquent bills must be paid in full before your application can be processed.

Please make arrangements to pay all outstanding bills to the Tax Collector’s Office.

Tax Collector’s Office – Name (Please Print)	Initial	Date	

**TOWN OF WRENTHAM
PLANNING BOARD**
WRENTHAM TOWN HALL
79 SOUTH STREET
WRENTHAM, MASSACHUSETTS 02093
P: (508) 384-5441 | F: (508) 384-3174
planning@wrentham.ma.us | www.wrentham.ma.us

**FORM 2
APPLICATION FOR APPROVAL OF A
PRELIMINARY SUBDIVISION PLAN**

Application No.: PP _____ Date: _____

1. OWNER OF RECORD: _____

FULL ADDRESS: _____

PHONE: _____ EMAIL: _____

Deed recorded in the Norfolk County Registry of Deeds Book/Page: _____

2. NAME OF APPLICANT (If Not Owner): _____

FULL ADDRESS: _____

PHONE: _____ EMAIL: _____

3. ENGINEER / LAND SURVEYOR: _____

FULL ADDRESS: _____

PHONE: _____ EMAIL: _____

4. NAME OF AGENT / CONTACT PERSON: _____

FULL ADDRESS: _____

PHONE: _____ EMAIL: _____

5. ZONING INFORMATION:

Zoning District: _____ Total Site Area: _____ Lot Frontage: _____

Assessor's Parcel Id(s): _____

Overlay Districts (check all that apply):

Aquifer Protection Special Use District Watershed Protection Floodplain District

Is any zoning relief being requested: Yes No

If yes, please explain: _____

6. PROJECT INFORMATION: Provide a brief narrative of the project (use separate sheet if necessary):

Site Access Street(s): _____

Number of Proposed Lots: _____ Proposed Area of Lots: _____

Linear Feet of Roadway(s): _____ Proposed new roads: Public Private

Will the project require removal of soils from the site? Yes No

If yes, how many cubic yards and where is the soil being relocated: _____

In a general manner, describe the system of drainage: _____

Does the project affect any of the following?:

- Important wildlife habitats and /or outstanding botanical features?
- Historic sites/buildings eligible or listed on the Federal/State Historic Register?

Is the proposed work located within 25 ft. or 100 ft. of a wetland and/or 200 ft. of a stream/river?

7. AFFIDAVIT by Engineer / Land Surveyor who stamped/signed the plan that all items required per Section 3.312 of the Wrentham Rules & Regulations are shown (enclose attested document).

I, _____ hereby attest that all above information, required by Wrentham's Rules and Regulations Governing the Subdivision of Land, is accurately and completely shown on the Preliminary Subdivision Plan dated _____, regarding MAP(s) _____ LOT #(S) _____ located on _____ in the Town of Wrentham.

Engineer/Land Surveyor's Signature: _____

8. REQUIRED SIGNATURES:

- Both required signatures 8A and 8B must be obtained prior to submission.
- Required signatures are the responsibility of the Applicant.

- Failure to obtain all required signatures may cause a delay in processing.

8.A. APPLICANT AND/OR OWNER: Both the Applicant and at least one Property Owner signature must be submitted.

The undersigned, being the APPLICANT and OWNER(S) named above and as defined under Chapter 41, Section 81-L, hereby submits said plan as a PRELIMINARY plan in accordance with the Rules & Regulations of the Wrentham Planning Board and certifies that, to the best of the APPLICANT’S knowledge and belief, the information contained herein is correct and complete and that said PLAN conforms with the requirements of the Rules & Regulations

Applicant’s Signature _____ Date: _____

Property Owner’s Signature _____ Date: _____
(If Not Applicant)

8.B. TAX COLLECTOR *(To be completed by the Tax Collector)*

Note: Delinquent bills must be paid in full before your application can be processed. Please make arrangements to pay all outstanding bills to the Tax Collector’s Office.

The Office of the Tax Collector verifies that there are no outstanding taxes due by the Property Owner to the Town of Wrentham, MA.

Tax Collector’s Office – Name (Please Print)	Initial	Date
--	---------	------

TOWN OF WRENTHAM
PLANNING BOARD
WRENTHAM TOWN HALL
79 SOUTH STREET
WRENTHAM, MASSACHUSETTS 02093
P: (508) 384-5441 | F: (508) 384-3174
planning@wrentham.ma.us | www.wrentham.ma.us

FORM 3
APPLICATION FOR APPROVAL OF A
DEFINITIVE SUBDIVISION PLAN

Application No.: DP _____ Date: _____

1. OWNER OF RECORD: _____

FULL ADDRESS: _____

PHONE: _____ EMAIL: _____

Deed recorded in the Norfolk County Registry of Deeds Book/Page: _____

2. NAME OF APPLICANT (If Not Owner): _____

FULL ADDRESS: _____

PHONE: _____ EMAIL: _____

3. ENGINEER / LAND SURVEYOR: _____

FULL ADDRESS: _____

PHONE: _____ EMAIL: _____

4. NAME OF AGENT / CONTACT PERSON: _____

FULL ADDRESS: _____

PHONE: _____ EMAIL: _____

5. ZONING INFORMATION:

Zoning District: _____ Total Site Area: _____ Lot Frontage: _____

Assessor's Parcel Id(s): _____

Overlay Districts (check all that apply):

Aquifer Protection Special Use District Watershed Protection Floodplain District

Is any zoning relief being requested: Yes No

If yes, please explain: _____

6. PROJECT INFORMATION: Provide a brief narrative of the project (use separate sheet if necessary):

Site Access Street(s): _____

Number of Proposed Lots: _____ Proposed Area of Lots: _____

Linear Feet of Roadway(s): _____ Proposed new roads: Public Private

Will the project require removal of soils from the site? Yes No

If yes, how many cubic yards and where is the soil being relocated: _____

In a general manner, describe the system of drainage: _____

Does the project affect any of the following?:

- Important wildlife habitats and /or outstanding botanical features?
- Historic sites/buildings eligible or listed on the Federal/State Historic Register?

Is the proposed work located within 25 ft. or 100 ft. of a wetland and/or 200 ft. of a stream/river?

7. AFFIDAVIT by Engineer / Land Surveyor who stamped/signed the plan that all items required per Section 3.312 of the Wrentham Rules & Regulations are shown (enclose attested document).

I, _____ hereby attest that all above information, required by Wrentham's Rules and Regulations Governing the Subdivision of Land, is accurately and completely shown on the Preliminary Subdivision Plan dated _____, regarding MAP(s) _____ LOT #(S) _____ located on _____ in the Town of Wrentham.

Engineer/Land Surveyor's Signature: _____

8. REQUIRED SIGNATURES:

- Both required signatures 8A and 8B must be obtained prior to submission.
- Required signatures are the responsibility of the Applicant.

- Failure to obtain all required signatures may cause a delay in processing.

8.A. APPLICANT AND/OR OWNER: Both the Applicant and at least one Property Owner signature must be submitted.

The undersigned, being the APPLICANT and OWNER(S) named above and as defined under Chapter 41, Section 81-L, hereby submits said plan as a PRELIMINARY plan in accordance with the Rules & Regulations of the Wrentham Planning Board and certifies that, to the best of the APPLICANT’S knowledge and belief, the information contained herein is correct and complete and that said PLAN conforms with the requirements of the Rules & Regulations

Applicant’s Signature _____ Date: _____

Property Owner’s Signature _____ Date: _____
(If Not Applicant)

8.B. TAX COLLECTOR *(To be completed by the Tax Collector)*

Note: Delinquent bills must be paid in full before your application can be processed. Please make arrangements to pay all outstanding bills to the Tax Collector’s Office.

The Office of the Tax Collector verifies that there are no outstanding taxes due by the Property Owner to the Town of Wrentham, MA.

Tax Collector’s Office – Name (Please Print) Initial Date

**TOWN OF WRENTHAM
PLANNING BOARD**

**FORM 4
COVENANT**

COVENANT made this _____ day of _____, by and between _____, recorded with the Norfolk County Registry of Deeds in Book _____, Page _____ and the Planning Board of the Town of Wrentham (*the "Planning Board"*).

WHEREAS, the Trust has submitted an application to the Planning Board for approval of a definitive plan for the Subdivision of Land off _____ entitled " _____ " dated _____, _____, last revised _____, _____, prepared by _____ (*the "Subdivision Plan"*); and

WHEREAS the Planning Board approved the Subdivision Plan, subject to certain conditions contained in the certificate of action, dated _____ and filed with the Wrentham Town Clerk on _____, _____ (*the "Certificate of Action"*)

NOW THEREFORE, in consideration of the approval of the Subdivision Plan without requiring a performance bond or other security, _____, hereby covenants and agrees for itself and its successors in title with Planning Board as follows:

1. The undersigned is the owner in fee simple absolute of all the land included in the subdivision and that there are no mortgages of record or otherwise on any of the land.
2. The undersigned will not sell or convey any lot in the subdivision or erect or place any permanent building on any lot until the construction of ways and installation of municipal services necessary to adequately serve such lot has been completed in accordance with the covenants, conditions, agreements, terms and provisions as specified in the following:
 - a. The Application for Approval of Definitive Plan (Form 3).
 - b. The Subdivision Control Law and the Planning Board's Rules and Regulations governing this subdivision.
 - c. The Certificate of Action and the Conditions of approval specified therein.

- d. The Subdivision Plan as approved and as qualified by the Certificate of Action.

However, a mortgagee who acquires title to the mortgaged premises by foreclosure of otherwise and any succeeding owner of the mortgaged premises or part thereof may sell or convey any lot prior to the construction of the portion of the improvements necessary to serve the lot but subject to the restriction that no permanent building shall be constructed on the lot until such portion of the improvements has been completed.

3. This covenant shall be binding upon the executors, administrators, devisees, heirs, successors, and assigns of the undersigned and shall constitute a covenant running with the land included in the subdivision and shall operate as restrictions upon the land. All work shall be performed in accordance with the Town of Wrentham Subdivision Rules and Regulations (WSRR) UNLESS SPECIFICALLY WAIVED, GRANTED OR MODIFIED by the Planning Board.
4. The particular lots within the subdivision shall be released from the foregoing conditions upon the recording of a certificate of performance executed by a majority of the Planning Board and enumerating the specific lots to be released.
5. Nothing herein shall be deemed to prohibit a conveyance by a single deed subject to this covenant, or either the entire parcel of land shown on the Subdivision Plan or of all lots not previously released by the Planning Board.
6. The undersigned agrees to record this Covenant with the Norfolk County Registry of Deeds and provide a copy of the recorded Covenant to the Planning Board prior to requesting its release, in whole or in part.
7. This Covenant shall be executed before endorsement of the approval of the Subdivision Plan by the Planning Board and shall take effect upon its recording at the Norfolk County Registry of Deeds.
8. A deed or any part of the subdivision in violation of this Covenant shall be voidable by the grantee prior to the release of the Covenant; but not later than three (3) years from the date of such deed, as provided in M.G.L. Chapter 41, Section 81-U.
9. Upon determination by the Planning Board or its authorized representatives that the construction of ways and installation of municipal services, as specified herein, have been satisfactorily completed in accordance with the Subdivision Plan, the Certification of Action and the Planning Board Rules and Regulations, the Planning Board shall release this covenant by an appropriate instrument, duly recorded. Upon performance of this Covenant with respect to any lot, the

Planning Board may release such lot from this Covenant by an appropriate instrument duly recorded.

10. Nothing herein shall prohibit the applicant from varying the method of securing the construction of ways and installation of municipal services from time to time or from securing by one, or in part by one and in part by another of the methods described in M.G.L., Chapter 41, Section 81-U, as long as such security is sufficient in the opinion of the Planning Board to secure performance of the construction and installation of municipal services.
11. All drainage facilities and associated structures, including pipe, loaming, and seeding, shall be completed in accordance with the Subdivision Plan prior to the release of any lot, or if security for completion of the subdivision improvements has been submitted, prior to the final release of such security.
12. All construction shown on the Subdivision Plan and authorized under the Certification of Action shall be completed within three (3) years following the date of endorsement of the Subdivision Plan, or twenty-four (24) months from the initiation of the related clearing and rough grading of land within the subdivision site, whichever is later, unless otherwise extended by the Planning Board. Failure to complete such construction within said three (3) year or 24 months period shall result in automatic rescission of the approval of the Subdivision Plan and render the Certification of Action null and void.
13. Approval by the Planning Board of the Subdivision Plan shall not be treated as, nor deemed to be, approved by the Board of Health for a permit for construction and use of any lot or any individual sewage septic system.
14. The undersigned agrees to reserve the fee interest in the roadways shown on the Subdivision Plan in any deed conveying one or more of the lots in the subdivision to any other party.

For title to the property, see Deed recorded with the Norfolk County Registry of Deeds in Book _____ and Page _____.

Description of Mortgages:
Assent of Mortgagees:

EXECUTED under seal this _____ day of _____, _____.

_____, As Trustee of

Signature of Majority of Members of Planning Board in the Town of Wrentham
(Wrentham Planning Board Members).

_____	_____
_____	_____
_____	_____
_____	_____

COMMONWEALTH OF MASSACHUSETTS

NORFOLK, SS.

Then personally appeared the above-named _____, as Trustee of the _____, and acknowledged the foregoing instrument to be his free act and deed, as Trustee as aforesaid, before me.

Notary Public

My Commission Expires

COMMONWEALTH OF MASSACHUSETTS

NORFOLK, SS.

Then personally appeared the above-named _____ being one of the above-named members of the Planning Board of the Town of Wrentham, and acknowledged the foregoing instrument to be the free act and deed of the Board, before me:

Notary Public

My Commission Expires

**TOWN OF WRENTHAM
PLANNING BOARD**

**FORM 5
CERTIFICATE OF RELEASE OF SURETY**

Date: _____

Subdivision Name: _____

Property Street Address: _____

Wrentham Assessor's Id(s): _____

Plans prepared by: _____

Recorded in Norfolk Registry of Deeds as Plan No. _____ of _____ in
Plan Book/Page _____

Dear Town Treasurer,

This is to certify that at a meeting of the Planning Board held on _____,
it was voted to release the following described surety:

In accordance with the above vote, please release said surety.

Very truly yours,

Wrentham Planning Board

cc: Applicant
Bank/Bonding Company

**TOWN OF WRENTHAM
PLANNING BOARD**

**FORM 6
CERTIFICATE OF RELEASE FROM COVENANT**

The construction of ways, installation of municipal services and other improvements called for in the approval by the Wrentham Planning Board of the Definitive Subdivision Plan entitled, " _____ " dated _____, revised through _____ and recorded as Plan No. _____ of _____, in Plan Book _____, Page _____ at the Norfolk County Registry of Deeds, having been fully completed with respect to the following lots: _____ the undersigned members, being a majority of the Wrentham Planning Board, hereby release the above enumerated lots from the restrictions as to sale and building specified in the Covenant dated _____ and recorded with Norfolk County Registry of Deeds in Book _____, Page _____.

Executed under seal this ____ day of _____.

Signature of Majority of Members of Planning Board in the Town of Wrentham
(Wrentham Planning Board Members).

COMMONWEALTH OF MASSACHUSETTS

NORFOLK, SS. _____,

Then personally appeared the above-named _____ being one of the above-named members of the Planning Board of the Town of Wrentham, and acknowledged the foregoing instrument to be the free act and deed of the Board, before me:

Notary Public

My Commission Expires

**TOWN OF WRENTHAM
PLANNING BOARD**

**FORM 7
INSPECTION OF CONSTRUCTION**

Subdivision Name: _____

Property Street Address: _____

Stationing: From: _____ To: _____

<u>CONSTRUCTION STAGES</u>	<u>DATE APPROVED</u>	<u>APPROVED BY</u>
1. Clearing / Grubbing	_____	_____
2. Rough Grading	_____	_____
3. Drainage	_____	_____
4. Sewers	_____	_____
5. Water Main	_____	_____
6. Underground Utilities	_____	_____
a. Electricity	_____	_____
b. Telephone	_____	_____
c. Gas	_____	_____
7. Sub Base Grading	_____	_____
8. Base Grading	_____	_____
9. Penetration	_____	_____
10. Bituminous Concrete Binder Course	_____	_____
11. Castings and Curb Inlets	_____	_____
12. Bituminous Concrete Surface Course	_____	_____
13. Curbing	_____	_____
14. Sidewalks	_____	_____
15. Shoulders (loamed & seeded)	_____	_____
16. Street Signs	_____	_____
17. Bounds	_____	_____
18. Final Clean-up	_____	_____

Notes: The items under (6) are to be approved as completed by a representative of each specific utility company. A letter authorizing said representative to make said approval shall be filed with the Board.

The approval of any stage is for the purpose of proceeding to the next stage and does not relieve the developer from repairing, correcting, renewing or replacing any defects or imperfections in the construction method or the quality of materials discovered before the final inspection.

Upon the completion of the Inspection of Construction, the Planning Board shall make a final inspection of the street and notify the developer in writing of any defects that must be corrected.

FORM 8
CONVEYANCE OF EASEMENTS AND UTILITIES

_____ of _____ County, Massachusetts ("Grantor"), for consideration of less than one hundred dollars, hereby grant(s), transfer(s) and deliver(s) to the Town of Wrentham, a municipal corporation with offices at 79 South Street, Wrentham, Norfolk County, Massachusetts, the following:

The perpetual right and easement to construct, inspect, repair, renew, replace, operate and forever maintain: (1) a sanitary sewer or sewers with any manholes, pipe, conduits and other appurtenances; (2) pipes, mains, conduits, valves and other appurtenances for the conveyance of water; (3) storm drains, catch basins, sumps, culverts, pipes, headwalls, conduits, swales, infiltration and/or detention basins or galleys with outlet controls substantially as depicted on the plan referenced below, and other appurtenances for the conveyance, treatment and infiltration of stormwater runoff, and to do all acts incidental thereto, upon, through, and under the following described land:

And, for the consideration aforesaid, the said grantor does hereby give, grant, sell, transfer and deliver unto the said grantee and its successors and assigns forever, all water and sewer mains, pipes, manholes, conduits, valves and all appurtenances thereto that are now or hereafter constructed or installed in, through or under the above-described land by the grantor and the grantor's successors and assigns.

The rights granted to the Town hereunder are granted in gross, and may be exercised in common with any similar rights that may be reserved by the Grantor for the benefit of the roadways shown on the above referenced plan for so long as the Grantor retains any ownership interest therein.

For grantor's title, see deed from _____ dated _____, and recorded in the Norfolk County Registry of Deeds, Book _____, Page _____.

This conveyance does not constitute a sale of all or substantially all of the assets of _____. [for corporate grantor only].

And _____, a banking corporation in _____ County, Massachusetts, the present holder of a mortgage on the above described land, which mortgage is dated _____, and recorded in said Deeds, Book _____, Page _____ for consideration paid, hereby released unto the said grantee and its successors and assigns forever from the operation of said mortgage, the rights and easements herein-above granted and assents thereto.

In witness whereof we have hereunto set our hands and seals this ___ day of _____

All owners must sign below:

COMMONWEALTH OF MASSACHUSETTS

NORFOLK, SS. _____,

Then personally appeared the above-named _____, and
acknowledged the foregoing instrument to be _____ free act and
deed, before me:

Notary Public

My Commission Expires

SCHEDULE G
PERFORMANCE SECURED BY DEPOSIT OF MONEY

Wrentham, Massachusetts

AGREEMENT made this date between the Town of Wrentham; (name of applicant), hereinafter referred to as “the applicant” (address of applicant), to secure construction of ways and installation of municipal services in the subdivision of land shown on a plan entitled **(Name of Subdivision)**, by (Name of designer) dated: _____, owned by: (Name of owner), (address of owner), (address or other identification of location), and showing (No.) proposed lots.

KNOW ALL MEN by these presents that the applicants hereby bind and obligate themselves, their heirs, or its executors, administrators, devisees, heirs, successors and assigns, jointly and severally to the Town of Wrentham, a Massachusetts municipal corporation, acting through its Planning Board, the sum of (dollar amount) dollars, and have secured this obligation by depositing with the Treasurer of the Town of Wrentham a deposit of money in the above sum to be deposited in a subdivision escrow account in the name of the Town of Wrentham. The deposit of money is to be used to insure the performance by the applicant of all covenants, conditions, agreements, terms and provisions contained in the following:

1. Application for Approval Definitive Plan (Form C), dated: (date of application);
2. The subdivision control law and the Planning Board’s Rules and Regulations governing this subdivision and dated: (date of subdivision rules and regulations which govern plan);
3. Conditions included in the Certificate of Approval issued by the Planning Board and dated: date of vote to approve);
4. The definitive plan as qualified by the Certificate of Approval; and
5. Other documents(s) specifying construction or installation to be completed, namely (specify other documents, if any, and list lots secured if only a part of the subdivision is secured by a deposit of money);

This agreement shall remain in full force and effect until the applicant has fully and satisfactorily performed all obligations or has elected to provide another method of securing performance as provided in M.G.L., Chapter 41, Section 81-U.

Upon completion by the applicant of obligations as specified herein, on or before (date when construction and installation is to be completed), or such later date as may be specified by vote of the Planning Board with a written concurrence of the applicant, the deposit of money including all interest accrued thereon shall be returned to the applicant by said Town of Wrentham and this agreement shall become void. In the event the applicant should fail to complete any stage of construction of ways and installation of municipal services as specified in this agreement and within the time

herein specified, the deposit of money may be applied in whole, or in part, by the Planning Board for the benefit of the Town of Wrentham to the extent of the reasonable cost to the town of completing such construction or installation as specified in this agreement. Any unused money and the interest accrued on the deposit of money will be returned to the applicant upon completion of the work by said town.

The Town of Wrentham acting by and through its Planning Board hereby agrees to accept the aforesaid deposit of money in the amount specified in this agreement as security for the performance of the project as aforesaid.

Any amendments to this agreement and/or to the aforesaid security shall be agreed upon in writing by all parties to this agreement.

IN WITNESS WHEREOF we have hereunto set our hands and seals this (date) of (month), (year).

Signature of Majority of Members of Planning Board in the Town of Wrentham
(Wrentham Planning Board Members).

Signature of Applicant

COMMONWEALTH OF MASSACHUSETTS

NORFOLK, SS.

Then personally appeared the above-named _____ being one of the above-named members of the Planning Board of the Town of Wrentham, and acknowledged the foregoing instrument to be the free act and deed of the Board, before me:

Notary Public

My Commission Expires

FORM H
PERFORMANCE SECURED BY A SURETY COMPANY

_____,
Wrentham, Massachusetts

AGREEMENT made this date between the Town of Wrentham; (name of applicant), hereinafter referred to as “the applicant” (address of applicant); and (name of surety company), a corporation duly organized and existing under the laws of the state of (state where incorporated) and having a usual place of business at address of surety company, hereinafter referred to as “the surety”, to secure construction of ways and installation of municipal services in the subdivision of land shown on a plan entitled (**Name of Subdivision**), by (Name of designer) dated: _____, owned by: (Name of owner), (address of owner), (address or other identification of location), and showing (No.) proposed lots.

KNOW ALL MEN by these presents that the applicant and the surety hereby bind and obligate themselves, their, or its executors, administrators, devisees, heirs, successors and assigns, jointly and severally to the Town of Wrentham, a Massachusetts municipal corporation, acting through its Planning Board, the sum of (dollar amount) dollars, and have secured this obligation by depositing with the Treasurer of said Town of Wrentham a surety bond to secure the above sum of money, said surety bond to be used to insure the performance by the applicant of all covenants, conditions, agreements, terms and provisions contained in the following:

1. Application for Approval Definitive Plan (Form C), dated: (date of application);
2. The subdivision control law and the Planning Board’s Rules and Regulations governing this subdivision and dated (date of subdivision rules and regulations which govern plan);
3. Conditions included in the Certificate of Approval issued by the Planning Board and dated: (date of vote to approve);
4. The definitive plan as qualified by the Certificate of Approval; and
5. Other documents(s) specifying construction or installation to be completed, namely, (specify other documents, if any, and list lots secured if only a part of the subdivision is secured by a surety company).

This agreement shall remain in full force and effect until the applicant has fully and satisfactorily performed all obligations, or has elected to provide another method of securing performance as provided in M.G.L., Chapter 41, Section 81-U.

Upon completion by the applicant of obligations as specified herein, or before (date when construction and installation is to be completed), or such later date as may be specified by vote of the Planning Board with the written concurrence of the applicant and the surety, the interest of the Town of Wrentham in such surety bond shall be released, the surety bond shall be returned to the surety, and this agreement shall

become void. In the event the applicant should fail to complete any stage of construction of ways and installation of municipal services as specified in this agreement and within the time herein specified, the surety bond may be enforced, in whole, or in part, by the Planning Board for the benefit of the Town of Wrentham to the extent of the reasonable cost to the town of completing such construction or installation as specified in this agreement. Any unused portion of the surety bond will be released and the unused portion of the surety bond will be returned to the surety upon completion of the work by said town.

The Town of Wrentham acting by and through its Planning Board hereby agrees to accept the aforesaid surety bond in the amount specified in this agreement as security for the performance of the project as aforesaid.

Any amendments to this agreement and/or to the aforesaid security shall be agreed upon in writing by all parties to this agreement.

IN WITNESS WHEREOF we have hereunto set our hands and seals this (day) of (month), (year).

Signature of Majority of Members of Planning Board in the Town of Wrentham
(Wrentham Planning Board Members).

Signature of Applicant

Signature of Authorized Representative
of the Surety

COMMONWEALTH OF MASSACHUSETTS

NORFOLK, SS.

Then personally appeared the above-named (name) being one of the above-named members of the Planning Board of the Town of Wrentham, the applicant, and the authorized representative of the surety, acknowledged the foregoing instrument to be the free act and deed of the parties before me:

Notary Public

My Commission Expires

SCHEDULE I
PERFORMANCE SECURED BY REGISTERED NEGOTIABLE SECURITIES
(BONDS, STOCKS, PUBLIC SECURITIES)

_____,
Wrentham, Massachusetts

AGREEMENT made this date between the Town of Wrentham; (name of applicant)., hereinafter referred to as “the applicant” (address of applicant), hereinafter referred to as “the applicant” of (address of applicant), to secure construction of ways and installation of municipal services in the subdivision of land shown on a plan entitled **(Name of Subdivision)**, by (Name of designer) dated: ____ , owned by: (Name of owner), (address of owner), (address or other identification of location), and showing (No.) proposed lots.

KNOW ALL MEN by these presents that the applicant and the surety hereby bind and obligate themselves, their, or its executors, administrators, devisees, heirs, successors and assigns, jointly and severally to the Town of Wrentham, a Massachusetts municipal corporation, acting through its Planning Board, the sum of (dollar amount) dollars, and have secured this obligation by depositing with the Treasurer of said Town of Wrentham an instrument of transfer to the Planning Board of said Town of Wrentham, duly acknowledged and prepared in a suitable form pursuant to the provisions of the Massachusetts General Laws for the following type of negotiable security (type of security), said instrument of transfer shall also specify the above sum of money as a security for performance by the applicant of construction of the ways and installation of municipal services in the aforesaid subdivision and, where apt, a new certificate shall also be deposited with said Treasurer. Said certificate shall be free from encumbrances and shall be issued pursuant to Chapter 156-B, Section 30, M.G.L. in the name of the Planning Board of said Town of Wrentham and shall express on its face that it is held as collateral security to insure the performance by the applicant of all covenants, conditions, agreements, terms and provisions contained in the following:

1. Application for Approval Definitive Plan (Form C), dated: (date of application);
2. The subdivision control law and the Planning Board’s Rules and Regulations governing this subdivision and dated: (date of subdivision rules and regulations which govern plan);
3. Conditions included in the Certificate of Approval issued by the Planning Board and dated: (date of vote to approve) ;
4. The definitive plan as qualified by the Certificate of Approval; and
5. Other documents(s) specifying construction or installation to be completed, namely, (specify other documents, if any, and list lots secured if only a part of the subdivision is secured by a surety company).

This agreement shall remain in full force and effect until the applicant has fully and

satisfactorily performed all obligations, or has elected to provide another method of securing performance as provided in M.G.L., Chapter 41, Section 81-U.

Upon completion by the applicant of obligations as specified herein, or before (date when construction and installation is to be completed), or such later date as may be specified by vote of the Planning Board with the written concurrence of the applicant, the interest of the Town of Wrentham in the aforesaid security shall be released and said security shall be returned, by appropriate instrument, to the applicant by the Town of Wrentham and this agreement shall become void. In the event the applicant should fail to complete any stage of construction of ways and installation of municipal services as specified in this agreement and within the time herein specified, the security, namely (type of security) may be negotiated in whole, or in part, by the Planning Board for the benefit of the Town of Wrentham to the extent of the reasonable cost to the town of completing such construction or installation as specified in this agreement. Any unused funds resulting from the negotiation of aforesaid security by the Town of Wrentham will be returned to the applicant upon completion of the work by said town.

The Town of Wrentham acting by and through its Planning Board hereby agrees to accept the aforesaid negotiable security, namely (type of security) as specified in this agreement as security for the performance of the project as aforesaid.

Any amendments to this agreement and/or to the aforesaid security shall be agreed upon in writing by all parties to this agreement.

IN WITNESS WHEREOF we have hereunto set our hands and seals this (date) of (month), (year).

Signature of Majority of Members of Planning Board in the Town of Wrentham
(Wrentham Planning Board Members).

_____	_____
_____	_____
_____	_____
_____	_____

Signature of Applicant

COMMONWEALTH OF MASSACHUSETTS

NORFOLK, SS. ,

Then personally appeared the above-named (name) being one of the above-named members of the Planning Board of the Town of Wrentham, the applicant, and the authorized representative of the surety, acknowledged the foregoing instrument to be the free act and deed of the parties before me:

Notary Public

My Commission Expires

Duplicate copy to:

- Applicant
- Corporation originally issuing the negotiable security
- Planning Board
- Town Clerk of Wrentham
- Town Treasurer of Wrentham
- Board of Selectman of Wrentham

NOTE: Many securities are available in two forms – registered and bearer. Registered securities bear the owner’s name and the issuing party keeps a record of the owner. Bearer securities are not registered as to ownership. Registered securities generally facilitate better safekeeping but can be bothersome and take time to sell since it would have to be re-registered. The bearer form of security is therefore preferable when the security is to change hands.

FORM J
PERFORMANCE SECURED BY BANK PASSBOOK

_____,
Wrentham, Massachusetts

AGREEMENT made this date between the Town of Wrentham; (name of applicant), hereinafter referred to as “the applicant” of (address of applicant), to secure construction of ways and installation of municipal services in the subdivision of land shown on a plan entitled “(name of subdivision)”, by (name of designer) dated: (date of plan), owned by: (name of owner), address: (address of owner) and showing (No.) proposed lots.

KNOW ALL MEN by these presents that the applicant and the surety hereby bind and obligate themselves, their, or its executors, administrators, devisees, heirs, successors and assigns, jointly and severally to the Town of Wrentham, a Massachusetts municipal corporation, acting through its Planning Board, the sum of (dollar amount) dollars, and have secured this obligation by depositing with the Treasurer of said Town of Wrentham a deposit of money for the above sum represented by Bank Passbook No. (No.) with an order drawn on the (name of Bank) Bank of (address of Bank), payable to the order of the Planning Board of the Town of Wrentham, said sum to be used to insure the performance by the applicant of all covenants, conditions, agreements, terms and provisions contained in the following:

1. Application for Approval Definitive Plan (Form C), dated: (date of application);
2. The subdivision control law and the Planning Board’s Rules and Regulations governing this subdivision and dated: (date of subdivision rules and regulations which govern plan);
3. Conditions included in the Certificate of Approval issued by the Planning Board and dated: (date of vote to approve) ;
4. The definitive plan as qualified by the Certificate of Approval; and
5. Other documents(s) specifying construction or installation to be completed, namely, (specify other documents, if any, and list lots secured if only a part of the subdivision is secured by a bank passbook).

This agreement shall remain in full force and effect until the applicant has fully and satisfactorily performed all obligations, or has elected to provide another method of securing performance as provided in M.G.L., Chapter 41, Section 81-U.

Upon completion by the applicant of obligations as specified herein, or before (date construction and installation is to be completed, as specified by applicant), or such later date as may be specified by vote of the Planning Board with the written concurrence of the applicant and the bank, the bank passbook shall be returned to the applicant by the Town of Wrentham and this agreement shall become void. In the event the applicant should fail to complete any stage of construction of ways and installation of municipal services as specified in this agreement and within the time herein specified, the funds

on deposit in the account represented by the aforesaid bank passbook and order drawn thereon may be applied in whole, or in part, by the Planning Board for the benefit of the Town of Wrentham to the extent of the reasonable cost to the town of completing such construction or installation as specified in this agreement. Any unused funds and the bank passbook will be returned to the applicant upon completion of the work by said town.

The Town of Wrentham acting by and through its Planning Board hereby agrees to accept the aforesaid bank passbook and order drawn thereon as security for the performance of the project; and

The (name) Bank of (address) hereby agrees not to release any funds from the account represented by the aforesaid bank passbook or otherwise amend or make a change to the aforesaid bank passbook or to the order drawn thereon without written agreement by the Planning Board.

Any amendments to this agreement and/or to the aforesaid security shall be agreed upon in writing by all parties to this agreement.

IN WITNESS WHEREOF we have hereunto set our hands and seals this (day) of (month), (year).

Signature of Majority of Members of Planning Board in the Town of Wrentham
(Wrentham Planning Board Members).

Signature of Applicant

Signature of Authorized Representative
of the _____ bank

COMMONWEALTH OF MASSACHUSETTS

NORFOLK, SS.

Then personally appeared the above-named (name) being one of the above-named members of the Planning Board of the Town of Wrentham, the applicant, and the authorized representative of the (name) Bank, acknowledged the foregoing instrument to be the free act and deed of the parties before me:

Notary Public

My Commission Expires

Duplicate copy to:

Applicant
(name) Bank
Planning Board
Town Clerk of Wrentham
Town Treasurer of Wrentham
Board of Selectman of Wrentham

FORM K
ASSIGNMENT OF SECURITY BY LENDER'S AGREEMENT

_____,
Wrentham, Massachusetts

AGREEMENT made this date between the Town of Wrentham; (name of applicant), hereinafter referred to as "the applicant" (address of applicant); and (Name of bank that has first mortgage), hereinafter referred to as "the lender" of (address of lender), to secure construction of ways and installation of municipal services in the subdivision of land shown on a plan entitled (**Name of Subdivision**), by (Name of designer) dated: _____, owned by: (Name of owner), (address of owner), (address or other identification of location), and showing (No.) proposed lots.

KNOW ALL MEN by these presents that the applicant and the Planning Board of the Town of Wrentham have executed a covenant, dated _____, recorded in the Norfolk Registry of Deeds, Book _____, Page ____; that the applicant has recorded a first mortgage with the lender dated _____, recorded at the Norfolk County Registry of Deeds, Book _____, Page ____, covering (area of plan that is covered by first mortgage) as shown on the above-referenced plan as security for the payment of a certain note in the principal sum of _____ dollars; and that the applicant and lender hereby bind and obligate themselves, their heirs, or its executors, administrators, devisees, heirs, successors and assigns, jointly and severally to the Town of Wrentham, a Massachusetts municipal corporation, acting through its Planning Board, in the sum of _____ dollars. Said sum of money is to be retained by the Lender to insure the performance by the applicant of all covenants, conditions, agreements, terms and provisions contained in the following:

1. Application for Approval Definitive Plan (Form C), dated: _____;
2. The subdivision control law and the Planning Board's Rules and Regulations governing this subdivision and dated: _____;
3. Conditions included in the Certificate of Approval issued by the Planning Board and dated: _____;
4. The definitive plan as qualified by the Certificate of Approval; and
5. Other documents(s) specifying construction or installation to be completed, namely: _____

This agreement shall remain in full force and effect until the applicant has fully and satisfactorily performed all obligations.

Upon completion by the applicant of obligations as specified in the following schedule, the interest of the Town of Wrentham in such funds retained by the lender shall be released, that portion of the agreement covering a specific stage of work shall become void, and the lender may disburse such funds which have been held as security for a

specific stage of work, to the applicant:

Sum to be retained by Lender	Stage of Construction or installation to be completed	Date When Construction and installation is to be completed
\$		
\$		
\$		

In the event the applicant should fail to complete any stage of construction of ways and installation of municipal services as specified in this agreement and within the time herein specified, any funds remaining undisbursed shall be made available in whole, or in part, by the lender to the Planning Board for the benefit of the Town of Wrentham to the extent of the reasonable cost to the town of completing such construction or installation as specified in this agreement. Any unused portion of such funds will be released by the Planning Board and may be disbursed by the lender to the applicant upon completion of the work by said town.

The Town of Wrentham acting by and through its Planning Board hereby agrees to release the following lots (lots no's, to be released from covenant) from the operation of the above referenced covenant given pursuant to Section 81-U of Chapter 41, the Subdivision Control Law without receipt of a bond or deposit of money and further to accept this agreement and the funds in the amount specified herein to be retained by the lender as security for the performance of the project as aforesaid. Upon delivery of this agreement to the Planning Board, said lots shall be released as herein specified.

The lender hereby agrees that none of the funds retained as security, as specified herein, shall be disbursed to the applicant without prior written release of said funds by the Planning Board.

Any amendments to this agreement and/or to the aforesaid security shall be agreed upon in writing by all parties to this agreement.

IN WITNESS WHEREOF we have hereunto set our hands and seals this (day) of (month), (year).

Signature of Majority of Members of Planning Board in the Town of Wrentham (Wrentham Planning Board Members).

Signature of Applicant

Signature of Authorized Representative
of the Lender

COMMONWEALTH OF MASSACHUSETTS

NORFOLK, SS.

,

Then personally appeared (name) being one of the above-named members of the Planning Board of the Town of Wrentham, the applicant, and the authorized representative of the (name) Bank, acknowledged the foregoing instrument to be the free act and deed of the parties before me:

Notary Public

My Commission Expires

Duplicate copy to:

- Applicant
- Lender
- Planning Board
- Town Clerk of Wrentham
- Town Treasurer of Wrentham
- Board of Selectman of Wrentham

APPENDIX B – FIGURES

Figure 1

Typical Cross Sections for Street Layouts

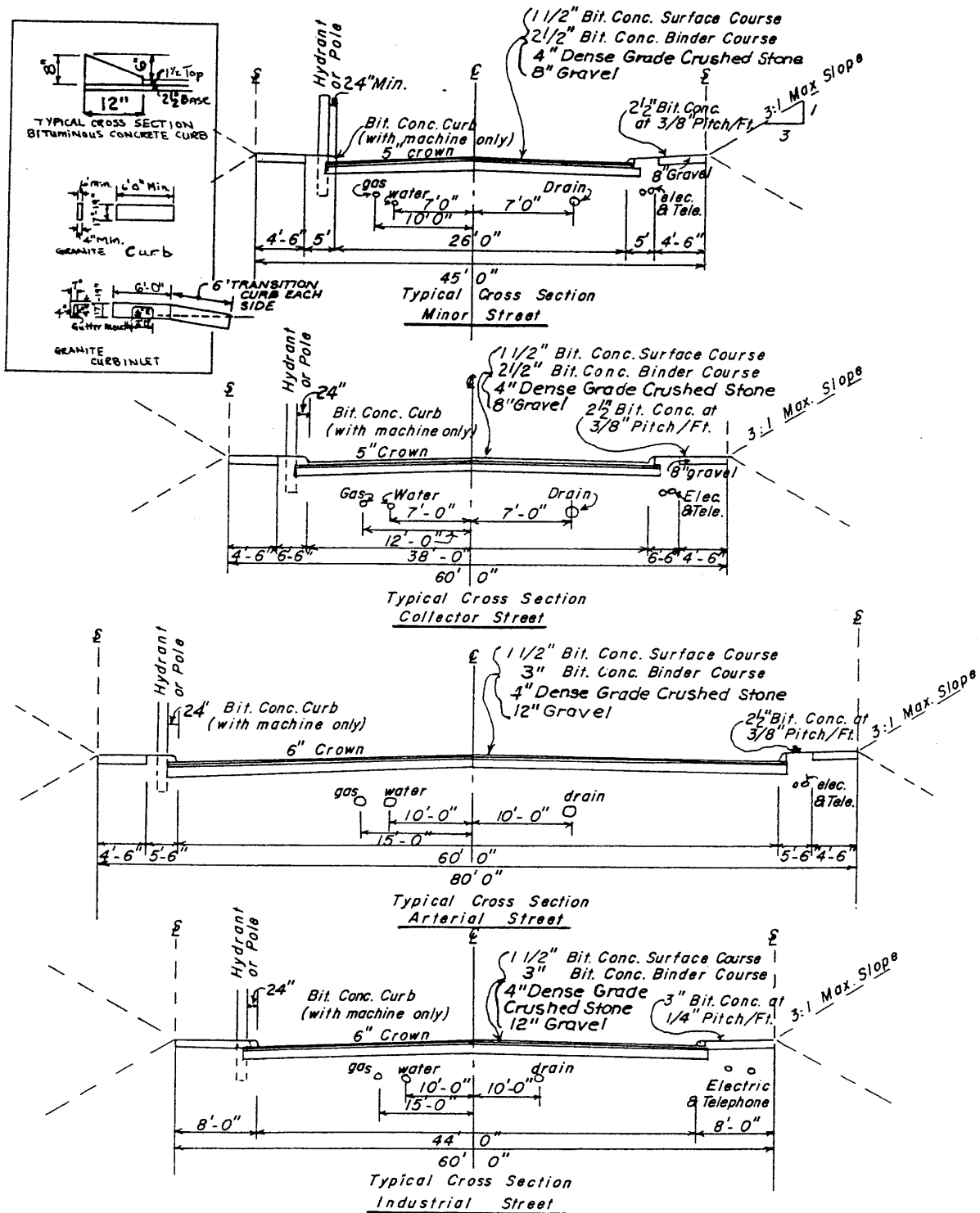

Figure 2

Typical Rotary Circle or Cul-de-Sac and Back-Up Strip

NOTE: Outline and extent of back-up strip shown dotted.

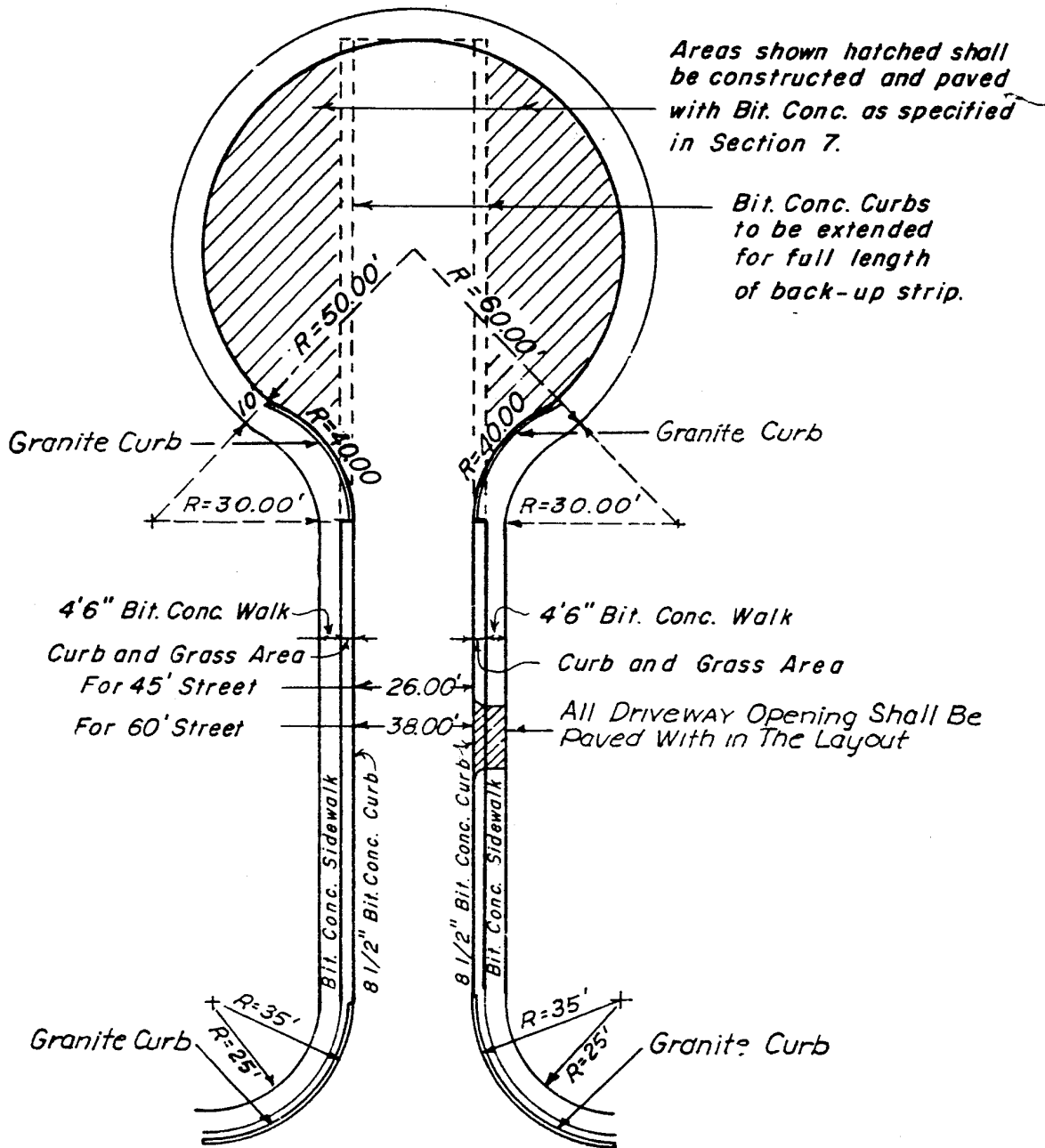

Figure 3
Rainfall Intensity Curve

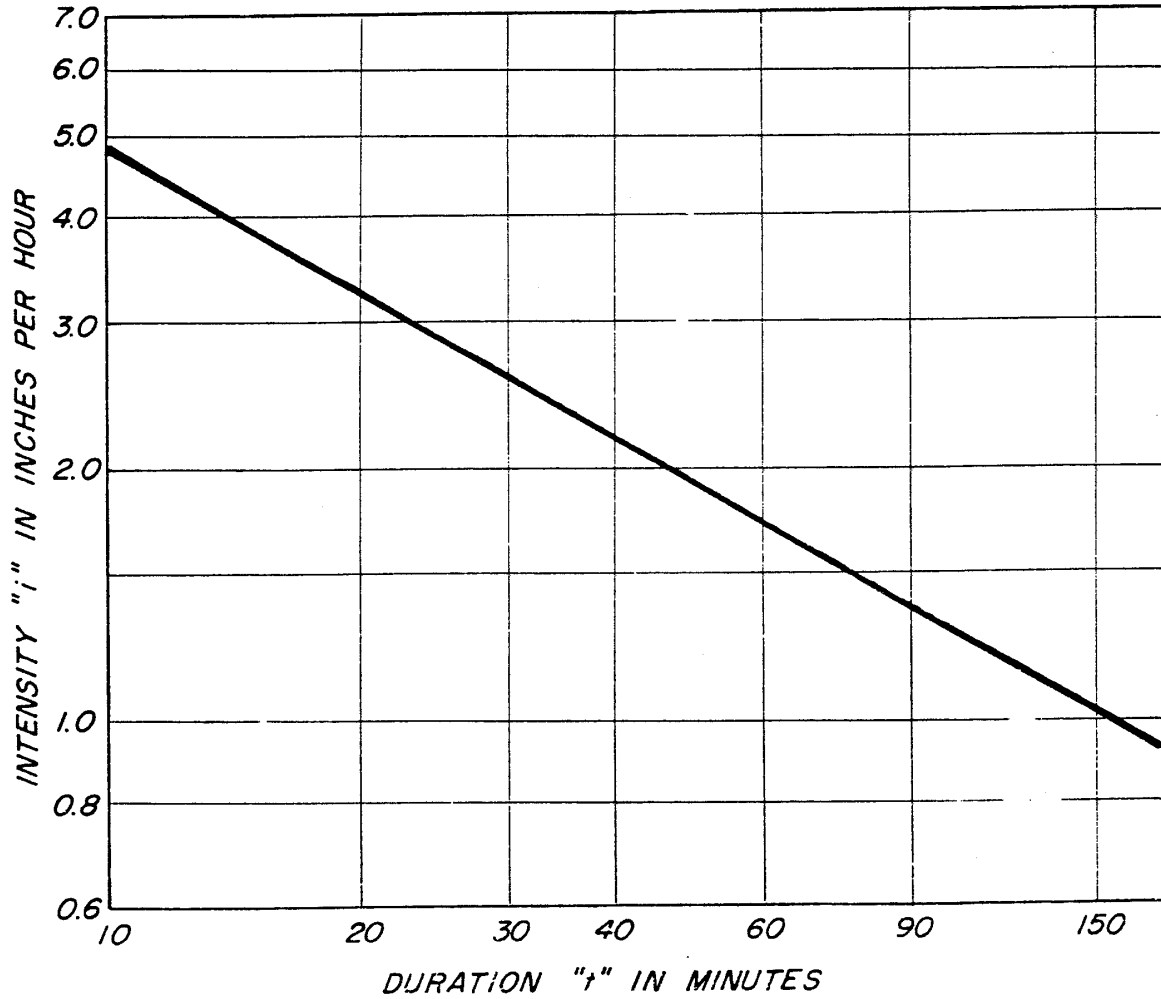

Figure 4
Standard Square Catch Basin Frame and Grate

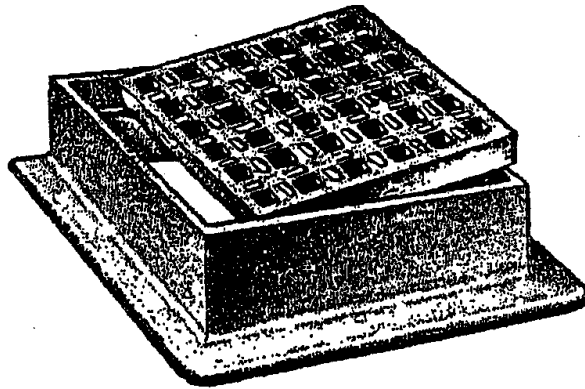
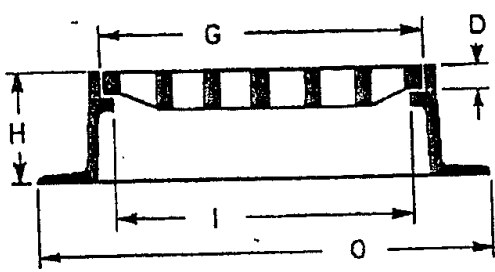
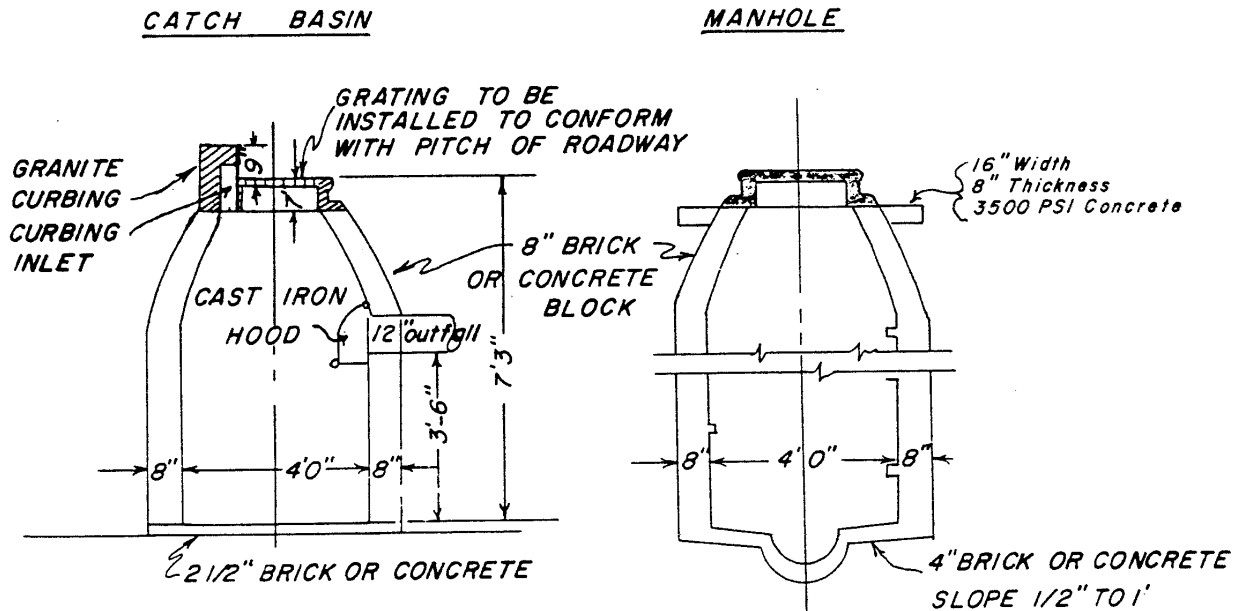

Figure 5
 Typical Cross Sections of Manholes, Catch Basins, and Subdrains



NOTE: MANHOLES & CATCH BASINS ARE TO BE CEMENT MORTAR PLASTERED ON THE OUTSIDE.

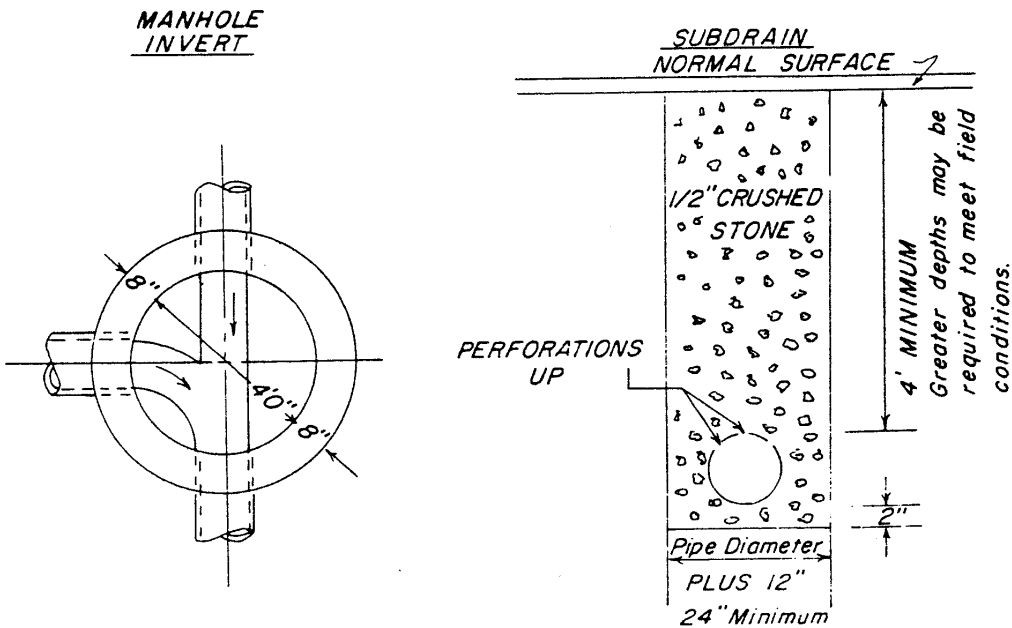

Figure 6
Types of Dead End Streets

Length of street measured from Point "A"
(i.e. intersection with THROUGH STREET) to Point "B".

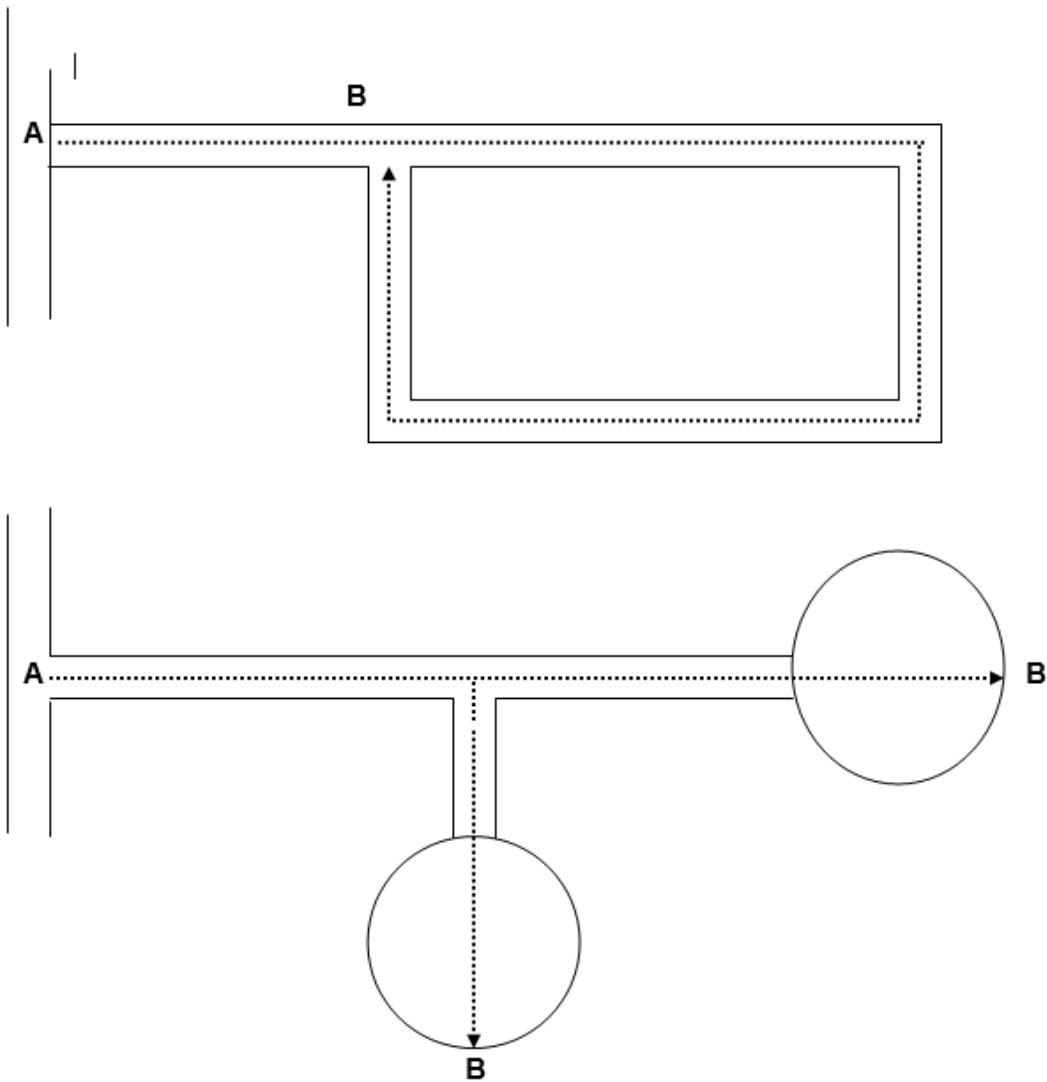
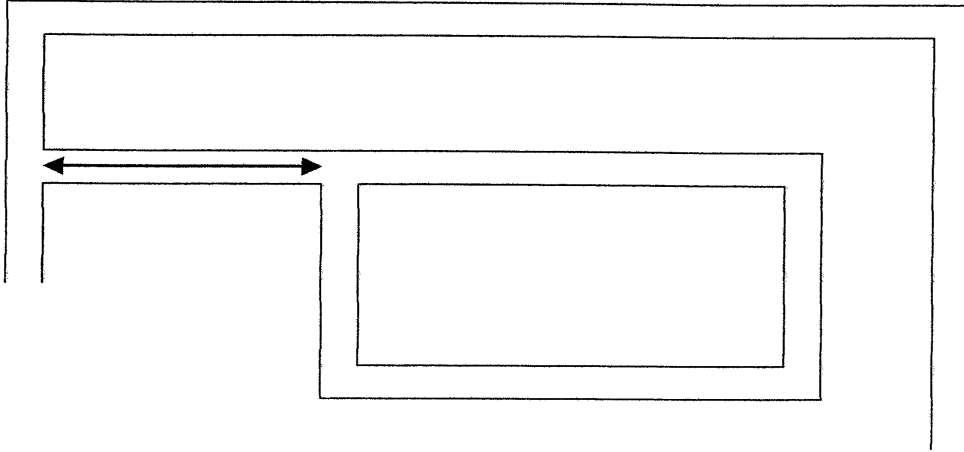

Figure 7
Comparison of Dead End vs. Through Streets

Example A – If vehicular access and egress to any particular location are restricted to one segment of the street network, then any street beyond and along where access and egress are so restricted shall be deemed a DEAD END STREET.



EXAMPLE B – If vehicular access and egress to any particular location can be accomplished along more than one segment of the street network, then any street along which this travel pattern can be accomplished shall be deemed a THROUGH STREET.

